

# BROOKFIELD YR-1 RHEOMETER

Operating Instructions

Manual No. M/02-215



SPECIALISTS IN THE  
MEASUREMENT AND  
CONTROL OF VISCOSITY

BROOKFIELD ENGINEERING LABORATORIES, INC.  
11 Commerce Boulevard, Middleboro, MA 02346-1031 USA

TEL 508-946-6200 or **800-628-8139** (USA only)  
FAX 508-946-6262 INTERNET [www.brookfieldengineering.com](http://www.brookfieldengineering.com)

# Contents

<b>I. INTRODUCTION .....</b>	<b>3</b>
I.1 Components .....	4
I.2 Utilities .....	4
I.3 Specifications .....	5
I.4 Installation .....	5
I.5 Key Functions .....	6
<b>II. GETTING STARTED .....</b>	<b>7</b>
II.1 Autozero .....	7
II.2 The Default Screen .....	8
II.3 Running A Program .....	8
II.4 Data Output .....	11
II.5 Printing A Program .....	12
II.6 Test Results .....	14
II.6.1 Test Passed .....	14
II.6.2 Test Failed .....	14
<b>III. EZ-YIELD SOFTWARE .....</b>	<b>16</b>
III.1 EZ-Yield Overview .....	16
III.2 EZ-Yield Quick Start .....	16
III.3 Test Parameter Description .....	17
III.4 Toolbar and Menu Options .....	18
III.5 Test Parameters Page .....	22
III.5.1 Pre-shearing .....	23
III.5.2 Zeroing .....	23
III.5.3 Wait Time .....	23
III.5.4 Run Speed .....	23
III.5.5 Base Increment .....	23
III.5.6 Torque Reduction .....	24
III.6 Data Page .....	24
III.7 Graphs Page .....	26
<b>IV. EXAMPLES .....</b>	<b>29</b>
APPENDIX A - Spindle and Model Codes .....	31
APPENDIX B - Speeds .....	32
APPENDIX C - Calibration Procedures .....	33
APPENDIX D - Calculations .....	37
APPENDIX E - Communications .....	39
APPENDIX F - Model S Laboratory Stand .....	41
APPENDIX G - DVE-50 Probe Clip .....	43
APPENDIX H - Fault Diagnosis and Troubleshooting .....	44
APPENDIX I - Warranty Repair and Service .....	48

# I. INTRODUCTION

The yield point is the point at which a material begins to flow. The associated properties are the yield stress and yield strain. The yield stress is the critical shear stress, applied to the sample, at which the material begins to flow as a liquid. The yield strain is the deformation, resulting from the applied stress, at which the flow starts.

Many materials are designed to have a yield point, so that the behavior of their products satisfies various customer needs. Foods often have yield points. Ketchup in particular must flow out of a bottle when shaken or squeezed, but then solidify on the targeted food such as french fries. Shaking or squeezing the bottle stresses the ketchup so that it flows; after the ketchup settles on the fries, its structure rebuilds so the ketchup “sits” in place rather than flowing off the fries like water. Puddings have yield points, as well. The “body” of the pudding appeals to consumers – it’s solid at rest, yet it’s easily spooned out of its cup and is easy to eat. Thus, the yield behavior of many foods contributes to the food texture that we like.

Many paints have low yield stresses. Many latex house paints, for example, are easily stirred or poured. Brushing or spraying provides enough stress so that the paint flows easily and smoothly over a painted wall. However, a thin layer of applied paint (if a good one!), allowed to rest undisturbed on the surface, regains its structure quickly so that there is very little unsightly “dripping” afterwards. The smooth appearance of the painted surface is very appealing to the homeowner.

The principal of operation of the YR-1 Rheometer is to drive a vane spindle (which is immersed in the test material) at very low rotational speed. The resistance of the material to movement is measured by observing increasing torque values as the YR-1 motor rotates faster than the spindle. The displacement of the material by the spindle is measured by the deflection of the calibrated spiral spring inside the instrument. Spring deflection is measured with a rotary transducer.

The shear stress measurement range of the YR-1 (in Pascals) is determined by the size and shape of the vane spindle, and the full scale torque of the calibrated spring.

There are three basic spring torque series offered by Brookfield:

<u>Model</u>	<u>Spring Torque</u>	
	<u>dyne-cm</u>	<u>milli Newton – m</u>
RVYR-1	7,187.0	0.7187
HBYR-1	57,496.0	5.7496
5XHBYR-1	287,480.0	28.748

The shear stress measurement range for each spring torque is as follows:

<b>Spindle</b>	<b>Torque Range</b>	<b>Shear Stress Range (Pa)</b>
V-71	RV	.5-5
V-72	RV	2-20
V-73	RV	10-100
V-71	HB	4-40
V-72	HB	16-160
V-73	HB	80-800
V-71	5xHB	20-200
V-72	5xHB	80-800
V-73	5xHB	400-4000

The equivalent units of measurement in the SI system are calculated using the following conversions:

	<u>SI</u>	=	<u>CGS</u>
Shear Stress:	1 Pascal or 1 Newton/m <sup>2</sup>	=	10 dyne/cm <sup>2</sup>
Torque:	1 Newton-m	=	10 <sup>7</sup> dyne-cm

## I.1 Components

The following items are included in your instrument kit:

<u>Component</u>	<u>Part Number</u>	<u>Quantity</u>
YR-1 Rheometer	varies, e.g. RVYR1-115 (115 volt YR-1 with RV spring torque)	1
Model S Laboratory Stand	MODEL S	1
Spindle Set with Case	SSVANE	1
V-71 spindle		1
V-72 spindle		1
V-73 spindle		1
Power Cord	DVP-65 for 115V or DVP-66 for 230V	1
RTD Temperature Probe	DVP-94Y	1
Carrying Case	DVE-7Y	1
EZ-Yield Software Disk (3-1/2")	YR1-4AY	1
Interconnecting Cable to PC	DVP-80	1
Operating Manual	M02/215	1
<i>Please check to be sure that you have received all components, and that there is no damage. If you are missing any parts, please notify Brookfield Engineering or your local Brookfield agent immediately. Any shipping damage must be reported to the carrier.</i>		

## I.2 Utilities

Input Voltage:	115 VAC or 230 VAC
Input Frequency:	50/60 Hz
Power Consumption:	Less than 20 WATTS
Power Cord Color Code:	

	<u>United States</u>	<u>Outside United States</u>
Hot (live)	Black	Brown
Neutral	White	Blue
Ground (earth)	Green	Green/Yellow

### I.3 Specifications

<b>Speeds:</b>	Pre Shear	0.01 to 200 rpm
	Zero	0.01 to 0.5 rpm
	Yield Test	0.01 to 5 rpm
<b>Time Intervals:</b>	100 msec – 1000 msec (1 sec)	
<b>Weight:</b>	Gross Weight	23 lbs. 10.5 kg.
	Net Weight	20 lbs. 9 kg.
	Carton Volume	1.65 cu. Ft. 0.05 m <sup>3</sup>
<b>Temperature sensing range:</b>	-100°C to 300°C (-148°F to 572°F)	
<b>Analog Torque Output:</b>	0 – 1 Volt DC (0 – 100% Torque)	
<b>Analog Temperature Output:</b>	0 – 4 Volts DC (10mV / °C)	
	RS232 Compatible Serial Port for use with an attached printer or PC.	
	Centronics Compatible Parallel Port for use with an attached printer.	
<b>Torque Accuracy:</b>	±1.0% of full scale range	
<b>Torque Repeatability:</b>	±0.2%	
<b>Temperature Accuracy:</b>	±1°C : -100°C to +149°C	
	±2°C : +150°C to +300°C	
<b>Electrical Certifications:</b>	CUL, CE	

### I.4 Installation

- 1) Assemble the Model S Laboratory Stand (refer to assembly instructions in Appendix H).
- 2) Connect the RTD probe to the socket on the rear panel of the YR-1.
- 3) The Rheometer must be leveled. The level is adjusted using the two leveling screws on the base. Adjust so that the bubble level on top of the YR-1 is centered within the circle.

**Note:** Check level periodically during use.

- 4) Remove the white shipping cap which secures spindle coupling nut on Rheometer to pivot cup.
- 5) Make sure that the AC power switch at the rear of the YR-1 is in the OFF position. Connect the power cord to the socket on the back panel of the instrument and plug it into the appropriate AC line. *The AC input voltage and frequency must be within the appropriate range as shown on the name plate of the Rheometer.*

**Note:** The YR-1 must be earth grounded to ensure against electronic failure!!

- 6) Turn the power switch to the ON position and allow to warm up for 10 minutes before performing autozero.

- 7) If appropriate, connect interconnecting cable to serial port for connection of YR-1 to PC or printer.
- 8) If appropriate, connect interconnecting cable to parallel port for connection of YR-1 to printer.
- 9) If appropriate, connect interconnecting cable to analog (serial) port for connection of YR-1 to chart recorder.

## I.5 Key Functions

The following explains the functions of the control keys on the face of the YR-1 Yield Rheometer.



### **UP ARROW**

Used to scroll UP (in an increasing direction) through the menu and program selections.



### **DOWN ARROW**

Used to scroll DOWN (in a decreasing direction) through the menu and program selections.



### **ENTER**

Used to accept or activate the current selection.



### **ESCAPE**

Used to cancel an operation or return to a previous screen.

**Note:** Selections are indicated as flashing text on the screen display.

## II. GETTING STARTED

This section explains how to use the YR-1 Rheometer in standalone mode. There are no test programs stored in instrument memory when the YR-1 is shipped from Brookfield. Therefore, you will need to review Section III on the EZ-Yield Software which explains how to create test programs. Once a test program has been downloaded from your PC to the YR-1, you will be able to run tests by following the instructions in this section.

### II.1 Autozero

Before any data may be taken, the rheometer must be Auto-zeroed. This action is performed each time the instrument is powered on. The display on the rheometer will guide you through the procedure as follows:

Set the power switch (located on the rear panel) to the **ON** position (press the **1** on the power switch) and allow to warm up for 10 minutes.

After applying power to the unit, the display will read:



```
BROOKFIELD YR-1  
YIELD RHEOMETER
```

*Figure 1*

This text is displayed for three (3) seconds after which the display will read:



```
BROOKFIELD YR-1  
RV Version 1.0
```

*Figure 2*

Figure 2 shows the instrument torque measurement range on the bottom left (in the case of Figure 2, RV) and the instrument firmware version number on the bottom right. This text is displayed for three (3) seconds after which the display will read:



```
REMOVE SPINDLE  
PRESS ANY KEY
```

*Figure 3*

After removing the spindle and pressing any key, the YR-1 begins its Auto-zero. The following is displayed during the auto-zero (with AUTOZEROING flashing):



```
AUTOZEROING  
PLEASE WAIT
```

*Figure 4*

When the auto-zero is complete, the Default Screen (Figure 5) is displayed.

## II.2 The Default Screen

The Default Screen is shown below:

```
#5 Sample Tst
START TEST  ↑↓
```

Figure 5

where the program number (#0 through #9) and the program name (in this case, “Sample Tst”) are displayed on the top line. START TEST is flashing indicating it is the current menu selection.

**Note:** If the program number chosen has no program loaded, the word EMPTY is displayed as the program name.

Pressing either the ↑ or ↓ key causes the bottom line to cycle between that shown in Figure 5 and Figure 6.

```
#5 Sample Tst
PRINT TEST  ↑↓
```

Figure 6

Pressing the ENTER key selects the option that is flashing causing the bottom line to stop flashing and the top line to start flashing. The top line is now the active line, allowing you to select which program to use. *Pressing the ESC key when Figure 5 or 6 is displayed has no effect.*

## II.3 Running A Program

When the Default Screen in Figure 5 is displayed and START TEST is the option displayed on the bottom line, pressing the ENTER key displays the following screen:

```
#5 Sample Tst↑↓
START TEST
```

Figure 7

**Note:** While the top line is the active selection line, the program number and name will always be flashing.

Pressing the ↑ or ↓ key scrolls through the program numbers (0-9) and displays the corresponding program name. While scrolling, if the slot scrolled to has no program in it, EMPTY is displayed next to the program number, and pressing the ENTER key has no effect.

Pressing the ESC key with this screen displayed causes the screen in Figure 5 to again be displayed (i.e. go back one level).

Once the sample is prepared and the ENTER key is pressed with a valid program displayed, the following screen is displayed:

```
USE SPINDLE #71
PRESS ENTER
```

*Figure 8*

where the two (2) digit spindle number is displayed on the top line. **Attach the appropriate spindle and lower it into the sample before continuing.**

Pressing the ENTER key with Figure 8 displayed performs the following:

- The test is started.
- The pre-test information (test parameters) is sent to both the serial (RS-232) port and to an attached printer via the parallel printer port. See section III.3 for a description of the pre-test information sent to the printer.
- The program number being run is recorded so that it will be the first program shown the next time that START TEST is selected from the Default Screen (Figure 5).

Pressing the ESC key at this screen causes Figure 7 to be displayed.

After ensuring the appropriate spindle is attached and pressing the ENTER key, the various Run screens are displayed. The top line of the Run screens always displays the program and spindle number as follows:

```
TEST #5 SPDL 71
-----
```

*Figure 9*

where the program and spindle numbers in use are displayed on the top line. The bottom line of the Run screens vary depending upon the options selected in the program.

Figure 10 is displayed when a Pre-Shear speed and time were selected. If the current program requires a Pre-shear step, the spindle will rotate at the selected speed for the selected time. The first field after the word **SHEAR** is the speed of the pre-shear (in rpm) while the second field is a time (in seconds) that counts down from the user defined pre-shear time. A Pre-shear step allows the sample to be conditioned before the actual test is started. In Figure 10, the pre-shear speed is 10 rpm and the pre-shear time is 30 seconds.

```
TEST #5 SPDL 71
SHEAR: 010 0030
```

*Figure 10*

Figure 11 is displayed when a Zero operation was selected. If the current program requires a Zero step, the spindle rotates backwards until the % torque reading is zero (0). The first field after the word **ZEROING** is the speed (in rpm) while the second field is the current % torque reading. A Zero step ensures that each test is started from 0% torque. In Figure 11, the speed is .2 rpm and the torque reading is momentarily at 2.4% as it decreases back to 0%.

```
TEST #5 SPDL 71
ZEROING:0.2 2.4
```

*Figure 11*

Figure 12 is displayed when a Wait Time was selected. A Wait Time step allows for a user-defined time delay before starting the test. The field after the word **WAIT** is the time (in seconds) that counts down from the user-defined wait time.

```
TEST #5 SPDL 71
WAIT 0010 SECS
```

*Figure 12*

Figure 13 is always displayed during the actual test, after the aforementioned preparation steps have been completed. During this portion of the test, data is continuously sent out the serial (RS-232 port) located on the rear panel of the instrument. This data is for use with the accompanying EZ-Yield software. See Section III.6 for more information regarding this data.

```
TEST #5 SPDL 71
RUNNING YIELD
```

*Figure 13*

If the ESC key is pressed at any time during the yield test run, the following is displayed:

```
TEST TERMINATED
BY USER
```

*Figure 14*

At this point, pressing the ENTER key starts the test again starting from whichever Run screen is applicable (Figures 10 through 13). Pressing the ESC key returns the display to that of Figure 8, reminding you which spindle should be used.

When the test is allowed to run to completion, one of the following screens (Figures 15 through 18) are displayed:

Figure 15 is displayed when the yield test passes. The % torque and stress (in Pa) at the point of yield are displayed along with the temperature (in °C) at the conclusion of test.

```
%=73.56 025.50
YIELD=726.36 Pa
```

*Figure 15*

Figure 16 is displayed when the yield test fails due to an over-range error (see Section II.6.2).

```

YIELD ERROR
OVER-RANGE

```

Figure 16

Figure 17 is displayed when the yield test fails due to an under-range error (see Section II.6.2).

```

YIELD ERROR
UNDER-RANGE

```

Figure 17

Figure 18 is displayed when the yield test fails due to the resultant yield stress exceeding the user defined limits. The limiting value causing the failed test (high or low yield stress) is displayed in the first field to the right of the **YLD:** while the resultant yield stress measured during the test is the second field.

```

LIMITS EXCEEDED
YLD:200 (726.36)

```

Figure 18

After screen 15 through 18 is displayed, pressing the ESC key returns the screen to Figure 8. At this point, after ensuring the appropriate spindle is attached, the ENTER key can be pressed to run the test again. Pressing the ENTER key when any of these screens is displayed immediately runs the test again and displays the first appropriate Run screen (Figures 10 through 13). When the test is complete, the results are sent out of both the parallel and serial (RS-232) ports.

**II.4 Data Output**

**II.4.1 Pre-Test Output**

When a test is begun, the following information is sent out both the parallel and serial (RS-232) ports in the format shown with each line terminated by a CR/LF:

```

Date : .....
Sample Information : .....
Operator : .....

```

```

Model : RV
YD1:Spindle : 71/001 YD2:Pre-shear (rpm/secs) : 0.1/0010
YD3:Zero (rpm) : 0.05 YD4:Wait Time (secs) : 0010
YD5:Run Speed (rpm) : 0.4 YD6:Base Inc. (msec) : 0200
YD7:Torque Red. (%) : 020 YD8:Under-Range Red. (%) : 050
YD9:Average (readings) : 05 YDA:Limits (Low/High)(Pa) : 00200/01000
Base Inc. Cal. (%) : 1.55 Temperature (°C) : 25.5
Test Name : Sample Tst Slot Number : 01

```

- NOTES:**
- 1) The **Base Inc. Cal.** (Base Increment Calibration) number is the change in torque expected for the **Base Inc.** (Base Increment) selected using the calibration data stored in the instrument.
  - 2) The YDx values are for use with the EZ-Yield software and can be ignored.

## II.4.2 Post-Test Output

At the conclusion of the test, one of the following six (6) messages is sent out both the parallel and serial (RS-232) ports:

1. Test (#test number: test name) Complete  
Yield Stress (Pa) = 196.53 % Torque @ Yield = 78.6 Temperature = 25.5C  
Test Passed
2. Test (#test number: test name) Complete  
Test Failed = Under-range (displayed if test fails due to an under-range condition; see Section II.6.2)
3. Test (#test number: test name) Complete  
Test Failed = Over-range (displayed if test fails due to an over-range condition; see Section II.6.2)
4. Test (#test number: test name) Complete  
Yield Stress (Pa) = 196.53 % Torque @ Yield = 78.6 Temperature = 25.5C  
Test Failed = Yield Stress Below Low Limit (displayed if test fails due to resultant yield stress being below low limit; see Section II.6.2)
5. Test (#test number: test name) Complete  
Yield Stress (Pa) = 196.53 % Torque @ Yield = 78.6 Temperature = 25.5C  
Test Failed = Yield Stress Above High Limit (displayed if test fails due to resultant yield stress being above high limit; see Section II.6.2)
6. Test (#test number: test name) Cancelled  
Test Failed = Cancelled By User (displayed if test fails due to cancellation by the user)

## II.5 Printing A Program

After selecting PRINT TEST (by pressing the **ENTER** key with PRINT TEST flashing on the bottom line) from the Default Screen (Figure 6), the following is displayed:

```
#X 000000000000 ↑↓
PRINT TEST
```

Figure 19

**Note:** While the top line is the active selection line, the program number and name will be flashing and the ↑ and ↓ keys will be displayed to the right of the program name.

Pressing the ↑ or ↓ key scrolls through the program numbers (0-9) and displays the corresponding program name. While scrolling, if the memory location scrolled to has no program in it, EMPTY is displayed and pressing the **ENTER** key has no effect.

Pressing the **ESC** key with this screen displayed causes the screen in Figure 6 to again be displayed (i.e. go back one level).

Pressing the **ENTER** key with a valid program selected displays the following screen:



Figure 20

Pressing the **ENTER** key at this screen causes the selected program information to be sent out the parallel printer port (located on the rear panel of the instrument).

Pressing the **ESC** key at this screen returns the display to that of Figure 19.

**Note:** No handshaking with the printer is performed (i.e. the instrument simply sends the data assuming the printer is ready to accept it).

Pressing the **ENTER** key also records the program number being printed so that it will be the first program shown the next time **PRINT TEST** is selected from the Default Screen (Figure 6).

After printing is complete, the screen returns to the display shown in Figure 19.

**Note:** Printing can only be accomplished using the parallel printer port. The serial port (RS-232) is strictly used for downloading programs and/or collecting yield data using the accompanying EZ-Yield software.

Test programs are printed in the following format:

---

```
Program Number/Name: #5/Sample Tst

Operator:                               Date:

Spindle Number: 71                      Multiplier : 002
-----

Preparation Parameters
-----

Pre-Shear Speed (rpm): 10                Pre-Shear Time (sec): 0030
Zero Speed (rpm): 0.2                    Wait Time (sec): 0010

Run Parameters
-----

Run Speed (rpm): 0.5                     Base Increment (msec): 0100
Torque Reduction (%): 100                 Under-range Reduction (%): 015
Average (readings): 05
```

---

## II.6 Test Results

### II.6.1 Test Passed

When a yield test runs successfully, the resultant Yield Stress (Pa), the % Torque value at the time of the yield and the Temperature at yield are printed.

```
Test (#5: Sample Tst) Complete  
Yield Stress (Pa) = 726.36   % Torque @ Yield = 73.56   Temperature = 25.5C
```

In addition, the results are shown on the display as follows:

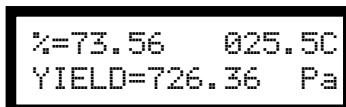

```
%=73.56  025.5C  
YIELD=726.36  Pa
```

Figure 21

### II.6.2 Test Failed

Some of the reasons a yield test may fail are as follows.

#### II.6.2.1 Under-Range Condition

Only yield measurements in the % Torque range from 10% to 100% will be accepted. If a Yield Stress is reached before the % Torque value is 10%, an Under-Range error causes the test to end.

The following is sent to an attached printer:

```
Test (#5: Sample Tst) Complete  
Test Failed = Under-range
```

The following screen is displayed:



```
YIELD ERROR  
UNDER-RANGE
```

Figure 22

#### II.6.2.2 Over-Range Condition

Only yield measurements in the % Torque range from 10% to 100% will be accepted. If Yield Stress is not reached before the measured % Torque value reaches 100%, an Over-Range error causes the test to end.

The following is sent to an attached printer:

```
Test (#5: Sample Tst) Complete  
Test Failed = Over-range
```

The following screen is displayed:



```
YIELD ERROR  
OVER-RANGE
```

Figure 23

### II.6.2.3 User-Defined Limit Condition

When an upper and lower limit has been imposed upon the Yield Stress by the user, any resulting Yield Stress that falls outside these limits causes the test to fail with a Limit Violation Condition. One of the following messages is sent to the attached printer dependent upon which limit was violated:

#### Low Limit Violation

```
Test (#5: Sample Tst) Complete  
Yield Stress (Pa) = 196.53 % Torque @ Yield = 27.4 Temperature = 250.5C  
Test Failed = Yield Stress Below Low Limit
```

#### High Limit Violation

```
Test (#5: Sample Tst) Complete  
Yield Stress (Pa) = 996.53 % Torque @ Yield = 78.6 Temperature = 250.5C  
Test Failed = Yield Stress Above High Limit
```

The following screen, showing first the violated limit value followed by the resulting Yield Stress, is displayed:



```
LIMITS EXCEEDED  
YLD:800 (996.53)
```

Figure 24

### II.6.2.4 Test Cancelled By User

When a test is cancelled by the user, either by pressing the ESC key during a running test or by canceling the test via the EZ-Yield software (See Section II.4.6), the following is sent to the attached printer:

```
Test (#test number: test name) Cancelled  
Test Failed = Cancelled By User
```

The following screen is displayed:



```
TEST TERMINATED  
BY USER
```

Figure 25

## III. EZ-YIELD SOFTWARE

Brookfield EZ-Yield software is a 32-bit Windows program supplied with every YR-1 Yield Rheometer.

### III.1 EZ-Yield Overview

EZ-Yield provides the following features:

- EZ-Yield allows you to easily create a yield test and download it to one of the ten (10) memory locations in the YR-1 Rheometer. These programs are retained in memory so that the YR-1 can be disconnected from the PC and used in remote locations (i.e. in a Q.C. laboratory, the production floor, etc.). Test programs can be saved and printed from the host PC.
- EZ-Yield collects all the data from a yield test run in addition to the final Yield Stress. This data can be saved, printed, and graphed using the software.

### III.2 EZ-Yield Quick Start

1. Ensure the YR-1 is powered on and ready to accept test programs (See Section II – Getting Started).
2. Ensure the appropriate serial (RS-232) cable (Brookfield Part # DVP-80) is connected to the serial port of the YR-1 and a serial port (COM port) on the host PC.
3. Start the EZ-Yield software in one of the following manners:
  - Click on its associated icon.
  - Click the Windows **Start** button. Select **Run**. Enter the name “ezyield.exe” of the program (including path) and click **OK** to execute EZ-Yield.
4. Once EZ-Yield is running, set the COM Port setting on the toolbar to the appropriate COM port.
5. Click on the **Test Parameters** tab beneath the toolbar. Select the appropriate values for all the test parameters listed at the left of the **Test Parameter** page. See Section III.3 for more information regarding how to select Test Parameters. Save the test parameters if desired by clicking the **Save** button or by clicking **Save** on the **File** menu.
6. Click the **Download** button on the toolbar or click **Download Program** in the **Utility** menu.
7. Ensure the appropriate spindle is attached to the YR-1 and that the sample is properly prepared.
8. Click the down arrow on the **Run** button or click **Run Program** on the **Utility** menu. Select the program number you wish to run, in this case, the Program Number specified in the list of Test Parameters.
9. After a few seconds, the **Graphs** page is automatically displayed signaling that the test has begun. Once all optional preparation steps are complete, the YR-1 begins sending data to the EZ-Yield software and displaying it on the graph and in the data table on the **Data** page.
10. When the test is complete, a dialog box appears asking you to save the data just acquired.

## III.3 Test Parameter Description

### III.3.1 Program Number

This is the number of the memory slot in the YR-1 Rheometer to which the test parameters will be loaded. There are ten (10) slots, numbered from 0 through 9.

### III.3.2 Program Name

This descriptive user-supplied name is loaded into the memory slot in the YR-1 Rheometer with the test parameters. A maximum of ten (10) alphanumeric characters may be used for this name.

### III.3.3 Spindle

#### Spindle Number

A two (2) digit code representing the spindle number used for the test must be selected. See Appendix A for more information regarding spindles for use with the YR-1 Rheometer. Selection of the appropriate spindle is important to ensure appropriate stress calculations.

#### Immersion Mark

Each vane spindle has two (2) immersion marks. The primary immersion mark is located on the spindle shaft. Normally, the spindle should be inserted so that the sample reaches this mark. If the sample container is too small to allow the spindle to be inserted to this mark, the secondary immersion mark may be used. This mark appears half way down the blades of the vane spindles. See Appendix A for more information regarding spindles and immersion marks.

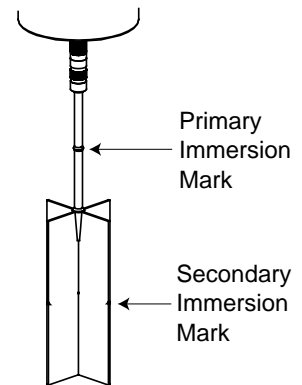

**Note:** Selection of the appropriate immersion mark is important to ensure appropriate stress calculations.

### III.3.4 Pre-Shear Information

An optional Pre-Shear step can be included in the test parameters. If the Pre-Shear box is checked on the Test Parameter page of the EZ-Yield software, a pre-shear step will be performed before running the actual test. The user must supply the speed and duration of the pre-shear step. See Appendix B for a complete list of pre-shear speeds.

### III.3.5 Zero

An optional, but highly recommended, torque Zero step can be included in the test parameters. If the Zero box is checked on the Test Parameter page of the EZ-Yield software, the rheometer will rotate the spindle in the appropriate direction until 0% torque is achieved. This step gives a consistent starting point for each test. A speed for the step must be supplied in the appropriate box. Faster speeds achieve a “zero” quicker but cause a more variable starting point. See Appendix B for a complete list of zero step speeds.

### III.3.6 Wait Time

An optional Wait step can be included in the test parameters. If the Wait Time box is checked on the Test Parameters page of the EZ-Yield software, just before the actual test run begins, there will be a time delay of the amount specified. During this delay, the spindle will be at zero (0) RPM.

### III.3.7 Run Speed

The speed at which the actual yield test is run. After any Pre-shear, Zero, and Wait time steps, the YR-1 motor shaft begins to turn at this speed. See Appendix B for a complete list of run speeds.

### III.3.8 Base Increment

This value is the time interval, in milliseconds, at which data is taken by the rheometer. This % torque data is used to determine when a yield point is reached. This value is automatically calculated by the EZ-Yield software and depends on the Run Speed selected. Although this value is calculated, it can be altered if there is a compelling need to do so. If the Base Increment has been manually altered for any reason, selecting a new Run Speed automatically resets the Base Increment to its optimum value.

### III.3.9 Torque Reduction

This parameter determines at what point the test ends. Generally, this value is set for 100%. A value of 100% causes the test to end when the delta torque (change in measured torque between consecutive readings) becomes zero (0). In a typical yield test, the delta torque readings will be steady until the sample begins to yield, indicated by decreasing delta torque values. When the delta torque drops to zero (0) (i.e. a change of 100% from the previous delta torque), the test is complete. Values greater than 100% will cause the test to continue after this “leveling off” point is reached. This occurs when delta torque values decrease further by an amount commensurate with the percentage the Torque Reduction was above 100% (Ex: a value of 110 waits for the “leveling off” at 100%, then continues until the additional decrease in delta torque is 10%).

### III.3.10 Low and High Yield Limits

These values (in Pa) can be used as a Quality Control tool. If the resulting yield stress from a test falls outside these limits, an appropriate message is displayed and printed with the results. Entering zero (0) for both these parameters disables this QC feature.

## III.4 Toolbar and Menu Options



**Note:** All functions shown on the toolbar can also be accessed from the menu above the toolbar.

### III.4.1 New

Selecting **New** (using the **New** button or the **New** option in the **File** menu) displays the **Test Parameters** page with default values in each field. Use this function before creating a new test program.

### III.4.2 Open

Selecting **Open** (using the **Open** button or the **Open** option in the **File** menu) displays the **Open File** dialog box.

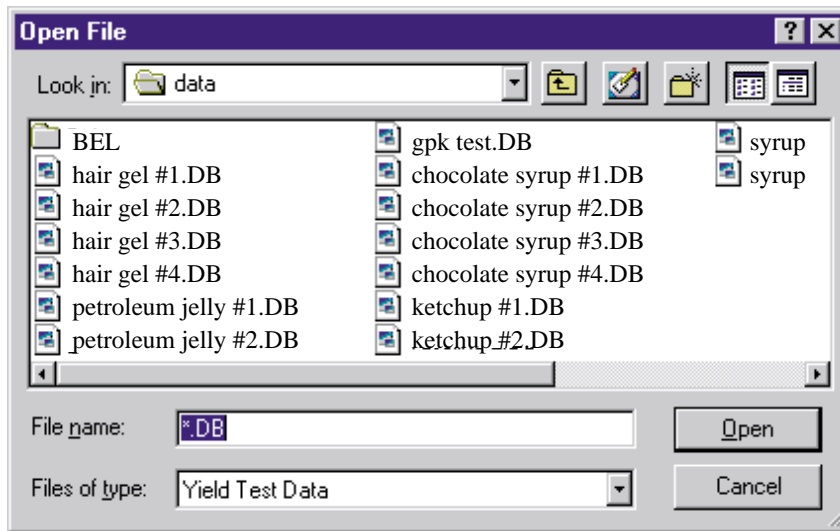

The **Open File** dialog box automatically displays files of the type it thinks the user requires; i.e. if the **Test Parameters** page was displayed, the file types displayed are test parameter files (\*.BYT) and if the **Data** or **Graph** pages were displayed, the file types displayed are data files (\*.DB). Regardless of the file types initially displayed, either type of file can be loaded by selecting the desired type at the bottom of the **Open File** dialog using the **Files of type** drop down list.

### III.4.3 Save

Selecting **Save** (using the **Save** button or the **Save** option in the **File** menu) displays the **Save File** dialog box.

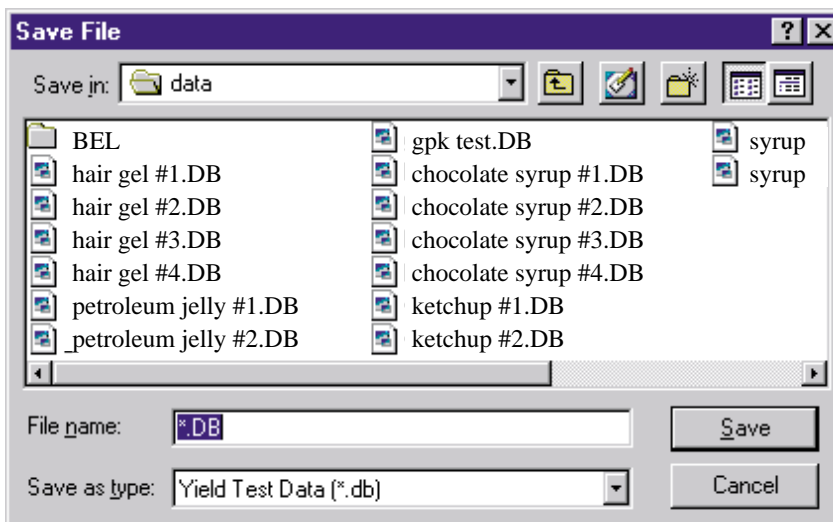

The **Save File** dialog box automatically displays files of the type it thinks the user requires (i.e. If the **Test Parameters** page was displayed, the file types displayed are test parameter files (\*.BYT) and if the **Data** or **Graph** pages were displayed, the file types displayed are data files.). Regardless of the file types initially displayed, either type of file can be saved by selecting the desired type at the bottom of the **Save File** dialog using the **Files of type** drop down list.





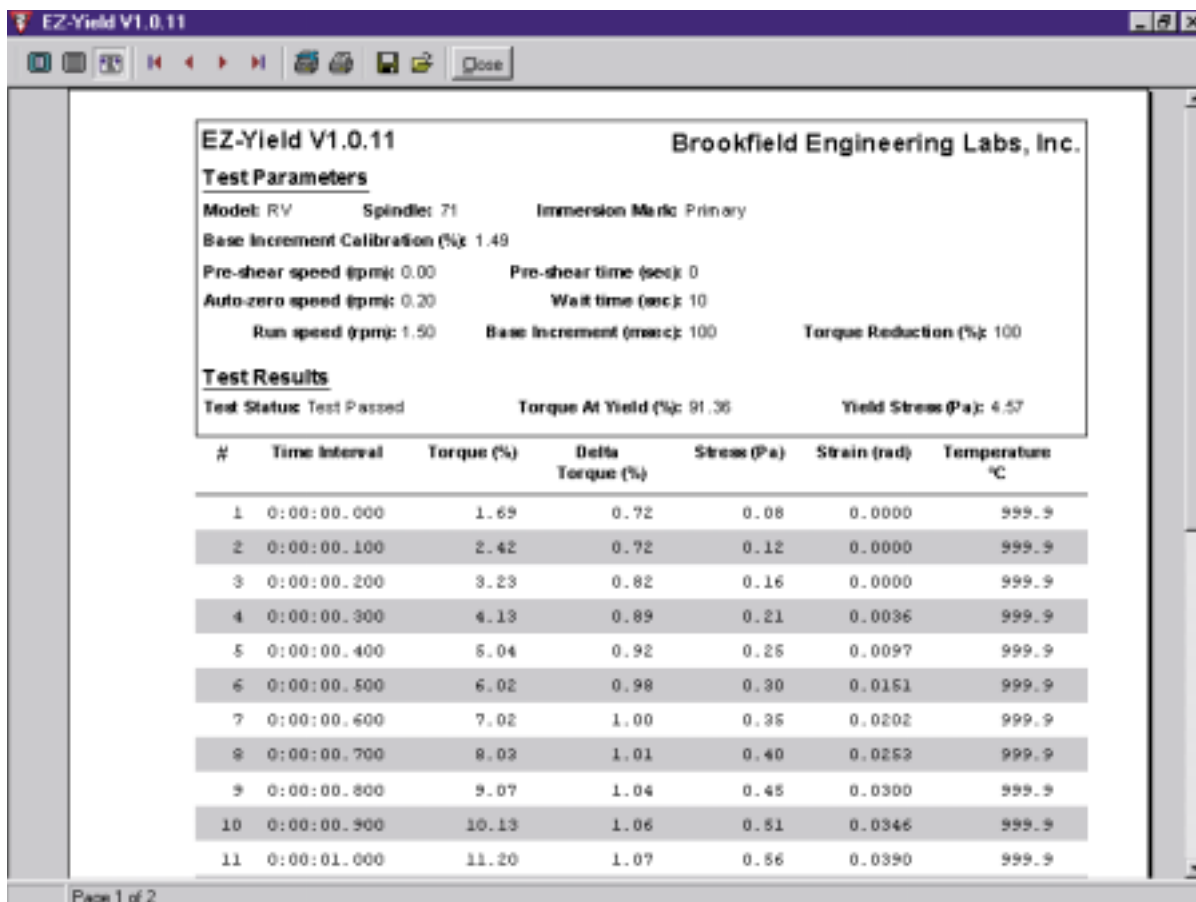



### III.4.4 Print

Selecting **Print** (using the **Print** button or the **Print** option in the **File** menu) displays a **Print Preview** window. Once this window is displayed, clicking the **Print** button sends the report to the selected printer. The functions of the buttons on the toolbar are described below:



The screenshot shows the EZ-Yield V1.0.11 software window. The title bar reads "EZ-Yield V1.0.11". The main content area is divided into sections: "EZ-Yield V1.0.11" and "Brookfield Engineering Labs, Inc." at the top. Below this is the "Test Parameters" section, which includes fields for Model (RV), Spindle (71), Immersion Mark (Primary), Base Increment Calibration (%), Pre-shear speed (rpm), Pre-shear time (sec), Auto-zero speed (rpm), Wait time (sec), Run speed (rpm), Base Increment (msec), and Torque Reduction (%). The "Test Results" section shows "Test Status: Test Passed", "Torque At Yield (%): 91.36", and "Yield Stress (Pa): 4.57". A table follows with columns for #, Time Interval, Torque (%), Delta Torque (%), Stress (Pa), Strain (rad), and Temperature (°C). The table contains 11 rows of data. At the bottom left, it says "Page 1 of 2".

#	Time Interval	Torque (%)	Delta Torque (%)	Stress (Pa)	Strain (rad)	Temperature °C
1	0:00:00.000	1.69	0.72	0.08	0.0000	999.9
2	0:00:00.100	2.42	0.72	0.12	0.0000	999.9
3	0:00:00.200	3.23	0.82	0.16	0.0000	999.9
4	0:00:00.300	4.13	0.89	0.21	0.0036	999.9
5	0:00:00.400	5.04	0.92	0.25	0.0097	999.9
6	0:00:00.500	6.02	0.98	0.30	0.0151	999.9
7	0:00:00.600	7.02	1.00	0.35	0.0202	999.9
8	0:00:00.700	8.03	1.01	0.40	0.0253	999.9
9	0:00:00.800	9.07	1.04	0.45	0.0300	999.9
10	0:00:00.900	10.13	1.06	0.51	0.0346	999.9
11	0:00:01.000	11.20	1.07	0.56	0.0390	999.9

-  **Zoom To Fit** Displays a complete page of the report in the window. Text and graphics are shrunk so that a complete page will fit on the screen.
-  **Zoom To 100%** Increases the size of all text and graphics so that they are displayed at 100% of their actual size.
-  **Zoom To Width** Displays a page so that the complete width of the page fits on the screen.
-  **First Page** Displays the first page of the report.
-  **Previous Page** Displays the previous page of the report.
-  **Next Page** Displays the next page of the report.
-  **Last Page** Displays the last page of the report.
-  **Printer Setup** Displays the standard Windows Print Setup dialog box. From this dialog box, a target printer can be chosen and its settings can be altered before printing.
-  **Print** Sends the report to the selected printer.

#### **Save Report**

Displays the Save Report dialog box allowing the report to be saved to a QuickReport (\*.QRP), Comma Separated Text (\*.CSV), HTML (\*.HTM), or Excel spreadsheet (\*.XLS) format.

#### **Load Report**

Previously saved reports can be loaded into the Print Report Preview window. *Only reports saved to the QuickReport (\*.QRP) format can be reloaded.*

### **III.4.5 Download**

Selecting **Download** (using the **Download** button or the **Download Program** option in the **Utility** menu) sends the parameters displayed on the Test Parameters page to the specified memory location in the YR-1 Rheometer. After a few seconds, a dialog box appears indicating that the rheometer received the parameters.

If no dialog box appears, see Appendix H – Troubleshooting – to help determine why the parameters were not received by the rheometer.

### **III.4.6 Run**

Selecting **Run** and a program number (using the **Run** button or the **Run Program** option in the **Utility** menu) directs the YR-1 Rheometer to run the selected program.

**Note:** The program numbers refer to the memory locations in the YR-1 Rheometer.

After a few seconds, the YR-1 tells EZ-Yield that the test has begun. Once all optional preparation steps have been performed by the rheometer, EZ-Yield begins to receive data as the test runs. If the **On-Line Plotting** option is selected in EZ-Yield, the **Graph** page is automatically displayed as soon as the first data point is received. Data is then plotted as it is received as well as being displayed in the **Data/Results** section of the **Data** page.

If the rheometer is running the test and no data appears, see Appendix H – Troubleshooting – to help determine why EZ-Yield is not receiving the data. When the test is complete, a dialog box is displayed asking you to save the freshly collected data and results.

### **III.4.7 Help**

Selecting **Help** (using the **Help** button or the **Help** option on the menu) displays the on-line help system.

### **III.4.8 Exit**

Selecting **Exit** (using the **Exit** button or the **Exit** option on the **File** menu) exits the EZ-Yield software. If test parameters or data have not yet been saved, a dialog box appears informing you of this fact and giving you the opportunity to save the pertinent information.

### **III.4.9 COM Port**

Select the COM Port on the host PC (sometimes referred to as a serial port or an RS-232 port) to which the YR-1 Rheometer is attached. COM1 through COM4 may be selected. Selecting NONE disconnects the rheometer from the host PC.

**Note:** Simply selecting the COM port is only part of what is needed for a valid connection between the rheometer and the host PC. Ensure that the appropriate cable is in use (Brookfield part # DVP-80) and that it is connected properly. See Appendix E – Communications – for more information regarding the YR-1 to host PC connection.

## III.5 Test Parameters Page

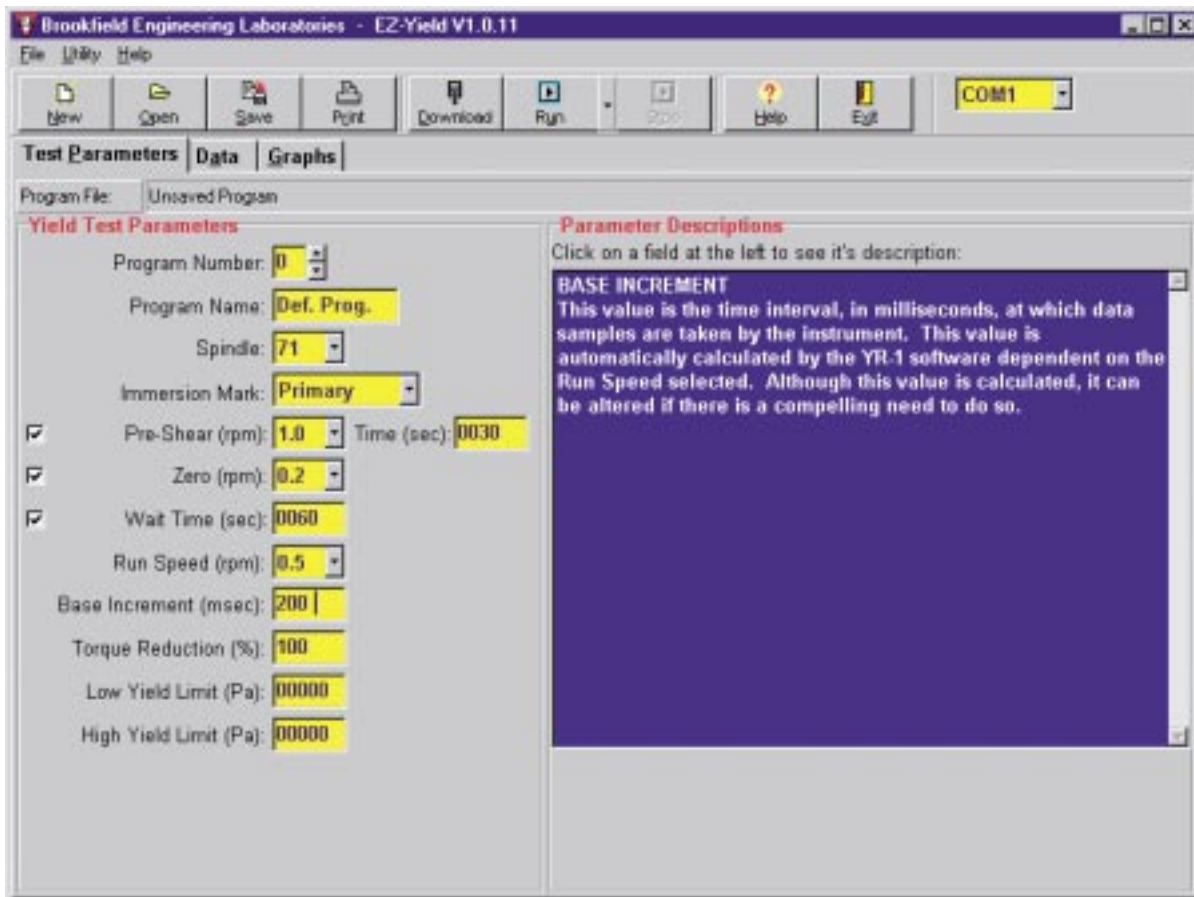

Use this page to create, load, save, and print test parameters that are then downloaded into one of the memory locations in the YR-1 Rheometer. The file name (including path) of the test parameters currently loaded is displayed at the top of the page.

Click on the entry field to edit the information in that field. The fields with downward pointing arrows on the right require that you click that arrow to make a selection from the drop down list. When a field is selected, the text on the right of the page, in the **Parameter Descriptions** box, changes to give information appropriate to the field selected. See Section III.3 – Test Parameter Description — for more information regarding each of the test parameters.

The **Pre-Shear**, **Zero**, and **Wait Time** steps are optional. Clicking the check box to the left of these fields until the check mark appears enables these parameters. Clicking the check box to the left of these fields until the check mark disappears disables these parameters.

Clicking the **New** button (or selecting **New** from the **File** menu) sets all parameters to their default values.

All open, save, and print operations selected while this page is displayed will open, save, and print test parameters and NOT data.

### **III.5.1 Pre-shearing**

*Pre-shearing* is the shearing of sample *before* measuring its yield properties. This process breaks down the sample's structure. It is particularly useful if the investigator wants to eliminate previous shear history (e.g., bumping, transferring) of the sample before testing and observe the structural rebuilding of the sample. This may simulate the following: ketchup pumped out of a bottle will rebuild after it comes to rest on the French Fries. There are materials whose measured yield stress will be lower after pre-shearing than if tested without pre-shearing. This may be used to compare the rate at which different materials rebuild. The yield stress measured in a pre-sheared sample is the "dynamic yield", while the yield stress measured for an originally undisturbed material is the "static yield".

Zeroing is, of course, a necessary step when pre-shearing is performed on the sample and is highly recommended for every test.

### **III.5.2 Zeroing**

*Zeroing* is the rotating of the motor drive in the YR-1 so that the torque at the start of the experiment is 0%. This is a desirable step because the spindle sometimes twists a small amount during insertion into the sample. This results in a small, although possibly significant, torque applied to the sample. Slow zeroing speeds are used to eliminate this initial torque and minimize effects on the sample's structure when the test is started.

Zeroing is an essential step after preshearing.

### **III.5.3 Wait Time**

*Wait Time* is the time the sample is allowed to rest between the completion of zeroing and the start of the yield measurement. Some samples rebuild structure more slowly than others after shearing, such as during handling, pouring sample into a beaker, etc. Certain low-viscosity paints may also have a low yield stress. Waiting 30 seconds, for example, after immersing the spindle may allow the sample to rebuild, producing a more consistent test method.

### **III.5.4 Run Speed**

*Run Speed* is the motor speed for the YR-1 at which the material is tested. It is common for materials to appear stiffer when tested at higher speeds. That is, the slope of the stress-vs.-strain curve increases with increasing speed. This is because the material structure has less time in which to react to dissipate the applied stress. Increasing the speed will, in most cases, increase the yield stress measured by the instrument. Most yield tests are conducted at relatively low speeds (<1 rpm) to minimize any inertial effects when using vane spindles.

### **III.5.5 Base Increment**

*Base Increment* is the amount of time between data points used for taking torque (stress) readings. The software automatically calculates base increment values. Smaller base increment values are used during faster speed tests to ensure that data are taken fast enough to properly determine the yield point. Larger base increment values are used during slower speed tests because these tests are expected to take longer and the longer time between data points helps prevent typical data files from becoming very large. However, the user may still wish to set this value to suit the required need after some familiarity is gained with the material being tested.

### III.5.6 Torque Reduction

*Torque Reduction* is the reduction in torque occurring at the defined yield point based on comparison to a rigid (solid) sample. That is, the material yields or begins to break down and, as a result, the measured incremental torque begins to decrease. A value of 100% for this parameter causes the test to stop as soon as there are no torque increases during a base time increment. Some users may wish to see a drop in torque after the yield point. Setting this parameter to values greater than 100% allows data to be collected after the yield point by the EZ-Yield™ software so the decrease in torque may be more easily visualized.

### III.6 Data Page

The screenshot displays the EZ-Yield V1.0.11 software interface. The window title is "Brookfield Engineering Laboratories - EZ-Yield V1.0.11". The interface includes a menu bar (File, Utility, Help) and a toolbar with icons for New, Open, Save, Print, Download, Run, Stop, Help, and Exit. The "Data" tab is selected, showing the "Data File" path: C:\YR1\EZ-Yield\data\chocolate.srup.D6.

The interface is divided into two main sections: "Parameters Used to Collect Data" on the left and "Data/Results" on the right.

**Parameters Used to Collect Data:**

- Model: RV
- Spindle: 71
- Immersion Mark: Primary
- Pre-shear speed (rpm): 0.00
- Pre-shear time (sec): 0
- Zero speed (rpm): 0.20
- Wait Time (sec): 10
- Run Speed (rpm): 1.50
- Base Increment (msec): 100
- Torque Reduction (%): 100
- Low Yield Limit (Pa): 0
- High Yield Limit (Pa): 0
- Base Increment Calibration (%): 1.49

**Data/Results Table:**

Time	% Torque	Delta % Torque	Stress	Strain
0:00:01.300	14.37	1.03	0.72	0.0527
0:00:01.400	15.44	1.07	0.77	0.0571
0:00:01.500	16.50	1.06	0.83	0.0617
0:00:01.600	17.56	1.05	0.88	0.0662
0:00:01.700	18.61	1.06	0.93	0.0708
0:00:01.800	19.68	1.07	0.98	0.0753
0:00:01.900	20.72	1.04	1.04	0.0800
0:00:02.000	21.79	1.07	1.09	0.0844
0:00:02.100	22.82	1.03	1.14	0.0893
0:00:02.200	23.85	1.03	1.19	0.0941
0:00:02.300	24.88	1.04	1.24	0.0990
0:00:02.400	25.88	0.99	1.29	0.1042
0:00:02.500	26.90	1.03	1.35	0.1091

Record 20 of 53 Date/Time Data Was Taken: 11/9/2001 11:55:24 AM

Test Result: **Test Passed**

% Torque @ Yield: 91.36 Temperature (°C): 999.9

Yield Stress (Pa): 4.57

Use this page to load, save, print, and export data taken with the YR-1 Rheometer. The file name (including path) of the data currently loaded is displayed at the top of the page.

The test parameters used to collect the data are displayed on the left of the page in the box labeled **Parameters Used To Collect Data**.

Data is displayed on the right of the page in the box labeled **Data/Results**. All recorded data points are displayed in the table.

<b>Time</b>	Starting at the beginning of the Run cycle of the test, data is taken at an interval equal to the Base Increment parameter. Elapsed time since the beginning of the Run cycle is shown here in units of hours, minutes, seconds, and thousandths of seconds (H:MM:SS.SSS).
<b>% Torque</b>	This field displays actual measured % Torque value
<b>Delta % Torque</b>	This field displays the difference between the current % Torque value and the previous % Torque value. As the sample approaches its yield point, the Delta % Torque should begin to decrease. If the Torque Reduction for the test is 100%, the yield point occurs when Delta % Torque reaches zero (0).
<b>Stress</b>	This field displays the calculated Stress for each data point. The final Stress value (i.e. the Stress at the yield point) is the resultant Yield Stress. See Appendix D – Calculations – for the equation used to calculate Stress.
<b>Strain</b>	This field displays the Apparent Strain placed on the sample for each data point. More accurately, the Apparent Strain is the angular distance that the spindle lags behind the angular distance traveled by the motor shaft. See Appendix D – Calculations – for the equation used to calculate Strain.

The total number of records and the record that is highlighted in the data table are displayed below the data table. In addition, as each data point is highlighted, the date and time (to the nearest second) that the data point was recorded is displayed just below the data table.

Below this line, the actual test results are displayed.

<b>Test Result</b>	There are five (5) possible test results: <ol style="list-style-type: none"><li>1. Test Passed</li><li>2. Test Failed due to an Under-Range condition</li><li>3. Test Failed due to an Over-Range condition</li><li>4. Test Failed due to a User-Limit violation</li><li>5. Test Failed due to a user cancellation</li></ol>
--------------------	--

See Section II.6 – Test Results – for more information regarding these possible results.

<b>Temperature</b>	The temperature recorded at the conclusion of the test is displayed here in °C.
<b>% Torque @ Yield</b>	The %Torque value at the yield point is displayed here.
<b>Yield Stress</b>	The stress at the yield point is displayed here in Pascals (Pa).

Clicking the **Export** button displays the **Print Preview** window. From the **Print Preview** window, the Save Report button can be clicked to allow you to save the report to various other file formats.

**Note:** The Save Report dialog box allows reports to be saved to in QuickReport (\*.QRP), Comma Separated Text (\*.CSV), HTML (\*.HTM), and Excel spreadsheet (\*.XLS) formats.

See Section III.4.4 – Print – for more information regarding this window.

All open, save, and print operations selected while this page is displayed will open, save, and print data and NOT test parameters.

### III.7 Graphs Page

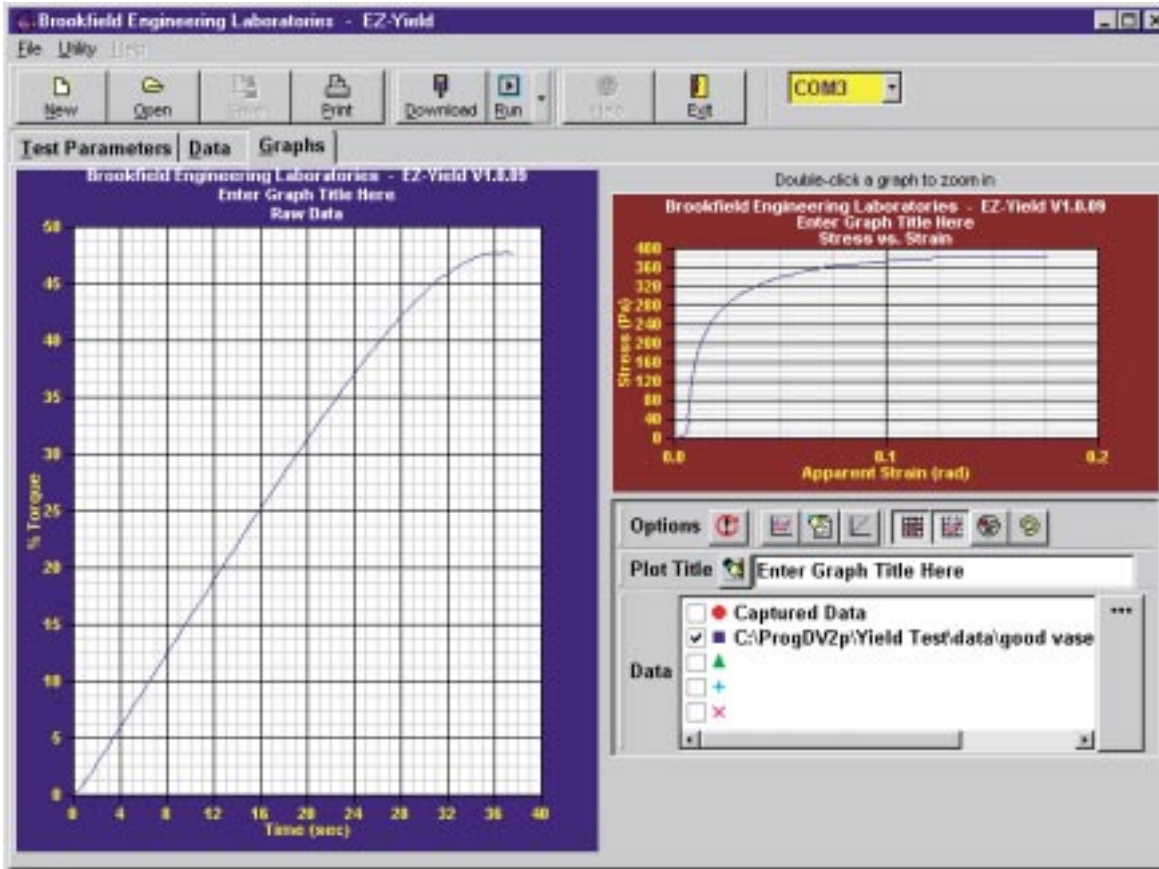

Use this page to graphically display yield test data both on-line (i.e. while the test is running) and after it is collected.

Two (2) graphs are displayed on this page.

1. % Torque vs. Time  
This graph displays the % Torque values versus the time (since the beginning of the **Run cycle**) at which the data points were collected. Torque is displayed in units of % while the Time is displayed in seconds.
2. Stress vs. Apparent Strain  
This graph displays the calculated Stress values versus the calculated Apparent Strain values for each data point collected. Stress is displayed in units of Pascals (Pa) while Apparent strain is displayed in units of radians (rad).

See Appendix D – Calculations – for more information regarding these calculated values.









Double-clicking on either graph enlarges or zooms that graph and displays it on the left side while shrinking the other graph and displaying it on the right.

The three (3) toolbars on the right side of the page can be resized and moved within the confines of the toolbar box by clicking and dragging the toolbar sizer located to the left of the toolbar title.

### Options Toolbar

**Note:** Many of the Options buttons are two (2) state buttons. Two (2) state buttons have two (2) positions: depressed and un-depressed. A visually depressed button indicates the option is turned ON while a visually un-depressed button indicates that the option is OFF. Clicking a two (2) state button causes its state to change, thereby turning an option ON and OFF.

The following is a functional description of each of the buttons on the Options toolbar of the Graphs page:

- |   |                         |  |
|---|-------------------------|--|
|    | <b>Replot</b>           | Click this button to refresh both graphs. Any time another option is changed, the <b>Replot</b> must be clicked to see those changes.  |
|    | <b>On-Line Plotting</b> | This is a two (2) state button. Turning this option ON causes data to be plotted on both graphs during the <b>Run cycle</b> of a yield test. Keep in mind that the YR-1 Rheometer must be communicating with the host PC and EZ-Yield in order for this data to be plotted.  |
|  | <b>Show Data Values</b> | This is a two (2) state button. Turning this option ON causes a hint box to be displayed whenever the mouse cursor is placed on one of the graphs within the data boundaries of the graph. This hint box displays the Time, % Torque, and Stress of the position pointed to by the cursor for the % Torque vs. Time graph and it displays Stress and Apparent Strain of the position pointed to by the cursor for the Stress vs. Strain graph. |
|  | <b>Calibration Data</b> | This is a two (2) state button. Turning this option ON causes the straight line, representing the calibration information of the rheometer, to be displayed along with the user data on the % Torque vs. Time graph.   |
|  | <b>Major Grid Lines</b> | This is a two (2) state button. Turning this option ON displays the major grid lines (those with a numerical representation on each axis) to be displayed.   |
|  | <b>Minor Grid Lines</b> | This is a two (2) state button. Turning this option ON displays the minor grid lines (those without numerical representation on each axis) to be displayed.  |
|  | <b>Data Markers</b>     | This is a two (2) state button. Turning this option ON displays a data marker (i.e. a colored shape matching that in the <b>Data</b> legend) for each data point.  |
|  | <b>Color Printouts</b>  | This is a two (2) state button. Turning this option ON allows graphs to be printed in color if an appropriately equipped printer is connected and properly configured in Windows.  |

Use the **Plot Title** two (2) state button to toggle between a user supplied graph title (the same title is used on both graphs) or a title indicating the yield test results. When the **Plot Title** button is depressed, the user supplied title is used.

**Note:** The Replot button must be clicked after making any changes to the state of the Plot Title button or to the user-supplied text.

### **Data Legend Toolbar**

This toolbar allows you to select multiple data sets to plot (up to 5) and select which color and marker to use for each data set. To select a data set to be plotted, click the box to the left of the marker so that a check mark is displayed. To un-select a data set so that it is not plotted, click the box to the left of the marker so that a check mark is NOT displayed. Once the appropriate data sets to be plotted are selected, click the **Replot** button in the **Options** toolbar to update the graphs.

The top line in the toolbar always displays **Captured Data** and cannot be changed. Select this data set to graph freshly collected (i.e. unsaved) data. The bottom four lines are used to select and load data from disk files. To select a file either double-click the intended line or select the line with a single click, then click the **Browse** button (i.e. the button with the three (3) dots or ellipsis). The **Open File** dialog box appears allowing you to navigate to and select the desired data file to graph.

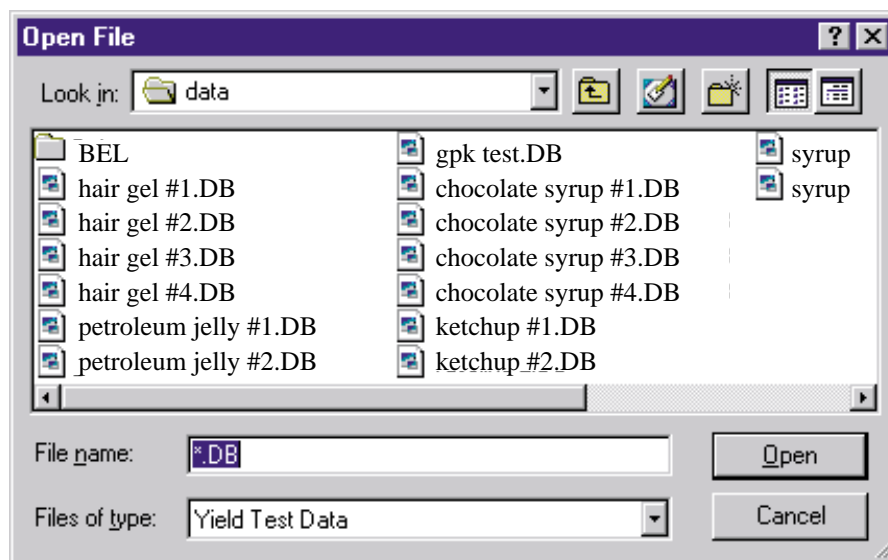

**Note:** The Replot button must be clicked after making any changes to the state of the Data Legend toolbar in order for the changes to be seen on the graphs.

On the graphs, the data is plotted using the color specified for the selected data sets in the **Data Legend** toolbar. In addition, if the Data Markers option is turned ON, the appropriate data marker from the legend is displayed on each graph for each data point.

## IV. EXAMPLES

Some users may download programs into the YR-1 using the EZ-Yield™ software and then use the instrument remotely without computer data acquisition, as discussed in Section II. However, other users may wish to acquire data with the EZ-Yield™ software and a personal computer to graphically analyze the sample material's behavior. Examples are presented below.

Figure IV-1 is a graph of Torque (%) vs. Time (seconds), and Figure IV-2 is a graph of stress (Pa) vs. strain ( $\gamma$ ). Data is presented for very different materials: cream cheese, mayonnaise, pudding and ketchup. Experimentally determining an appropriate combination of spring, spindle and speed for testing each material ensures that the torque readings were within the recommended 10-100% on the torque scale. If a sample has a relatively low torque reading for the yield (<10%), then try using a faster speed or larger spindle to get a larger torque reading. Furthermore, a YR-1 Rheometer with a more sensitive spring could be used as well; e.g. RVYR-1 instead of HBYR-1. You will need different spring torques in order to test a wide range of products that have vastly different yield characteristics. The spring torque of the HB is eight times greater than that of the RV and the 5xHB torque is 40 times greater than that of the RV (or five times that of the HB).

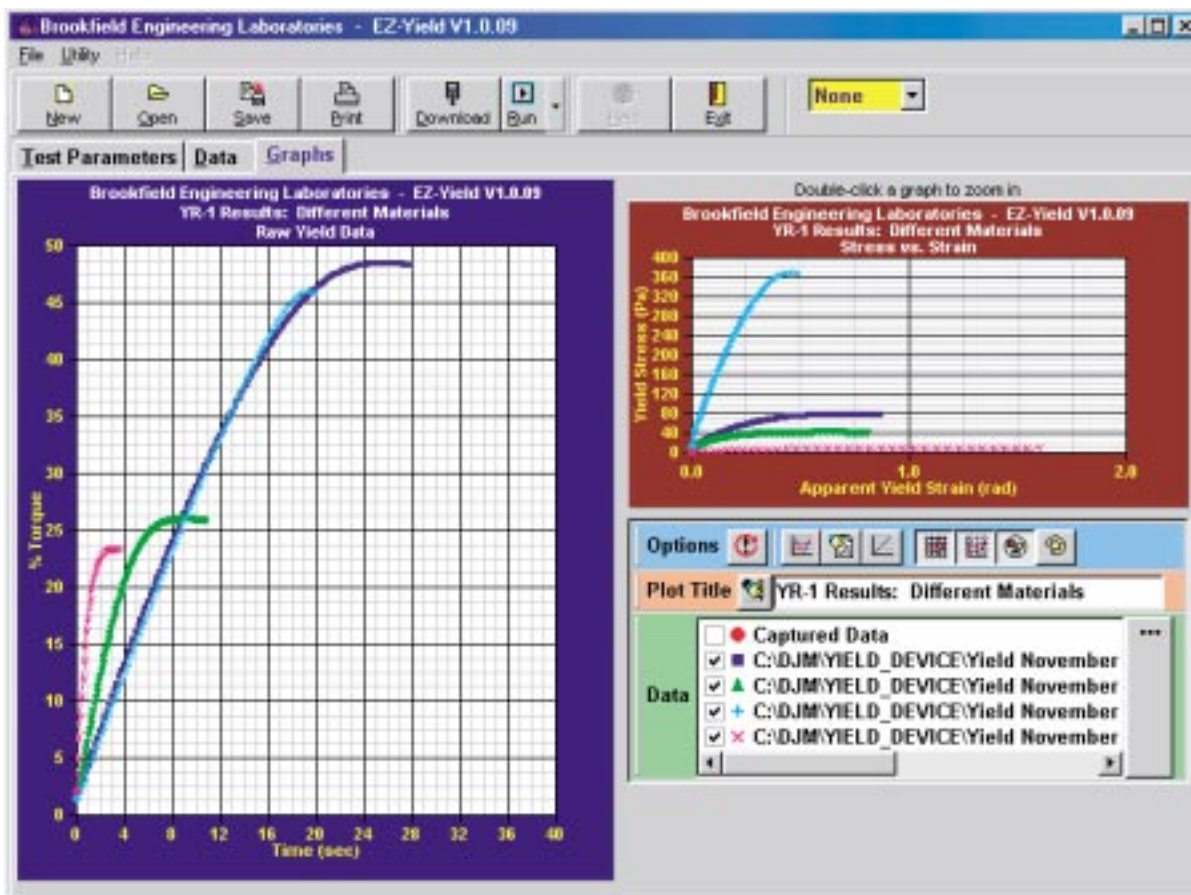

Figure IV-1: Torque vs. Time Graphs for Various Food Products

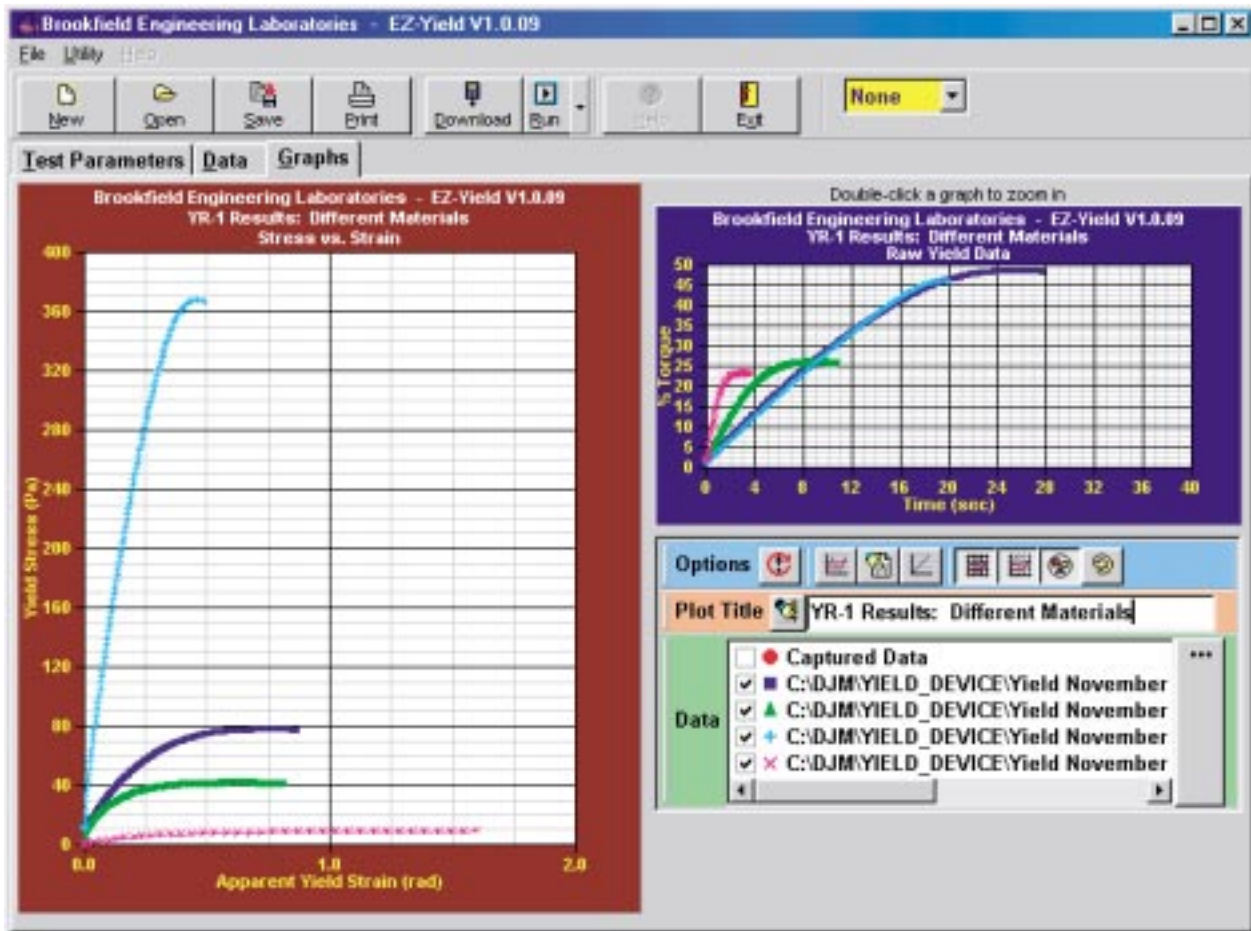

Figure IV-2: Stress vs. Strain Graphs for Various Food Products

## APPENDIX A - Spindle and Model Codes

Each spindle has a two (2) digit code which is selected via the EZ-Yield software. The code allows the YR-1 to calculate Yield Stress.

The immersion mark selected affects the stress calculations. Ensure the selected immersion mark reflects the mark in use.

Each spindle has a Yield Multiplier Constant (YMC) for stress calculations and a Spindle Multiplier Constant (SMC) for calibration checks as shown in Table A1. Spindle dimensions are also listed.

Spindle	Spindle Code	YMC	SMC	Vane Length		Vane Diameter	
				inches	cm	inches	cm
V-71	71	0.5	2.62	2.708	6.878	1.354	3.439
V-72	72	2.0	11.1	1.706	4.333	.853	2.167
V-73	73	10.0	53.5	.998	2.535	.499	1.267

Table A1

**Note:** If secondary immersion mark is selected, the YMC value is doubled.

Table A2 lists the model codes and spring torque constants (TK) for each Rheometer model.

Model	Tk	Model Code On YR-1 Screen
RVYR-1	1	RV
HBYR-1	8	HB
5HBYR-1	40	5HB

Table A2

The full scale Yield Stress range for any YR-1 model and spindle may be calculated using the equation:

$$\text{Full Scale Yield Stress Range (Pa)} = \text{TK} \times \text{YMC} \times 10$$

where:

TK = YR-1 Torque Constant from Table A2

YMC = Yield Multiplier Constant from Table A1

## APPENDIX B - Speeds

<b>Pre-Shear Speeds (RPM)</b>	
<b>Range</b>	<b>Increment</b>
0.01 to 0.09	0.01
0.1 to 5.0	0.1
6, 10, 12, 20, 30, 50, 60, 100, 200	N/A

<b>Zero Speeds (RPM)</b>	
<b>Range</b>	<b>Increment</b>
0.01 to 0.09	0.01
0.1 to 5.0	0.1

<b>Run Speeds (RPM)</b>	
<b>Range</b>	<b>Increment</b>
0.01 to 0.09	0.01
0.1 to 5.0	0.1

## APPENDIX C - Calibration Procedures

The torque sensing spiral spring in the YR-1 Rheometer is calibrated at Brookfield to be accurate within  $\pm 2\%$  of full scale range of a certified master viscometer. When checking calibration in the field with a vane spindle (spindle 71, 72, or 73) using the following procedures, an accuracy of  $\pm 2\%$  of full scale range can be expected.

The accuracy of the YR-1 is verified using viscosity standard fluids which are available from Brookfield Engineering Laboratories or your local Brookfield agent. Viscosity standards are Newtonian and, therefore, have the same viscosity regardless of spindle speed. Viscosity standards, calibrated at 25°C, are shown in Table C1 (Silicone Oils) and Table C2 (Mineral Oils).

GENERAL PURPOSE SILICONE FLUIDS	
BEL Part No.	Viscosity (cP) at 25°C
5 cps	5
10 cps	10
50 cps	50
100 cps	100
500 cps	500
1,000 cps	1,000
5,000 cps	5,000
12,500 cps	12,500
30,000 cps	30,000
60,000 cps	60,000
100,000 cps	100,000

*Table C1 - Silicone Viscosity Standard Fluids*

MINERAL OIL VISCOSITY STANDARD FLUIDS	
BEL Part No.	Viscosity (cP) 25°C
B31	31
B210	210
B750	750
B1400	1,400
B2000	2,000
B11000	11,000
B20000	20,000
B80000	80,000
B200000	200,000
B420000	420,000

*Table C2 - Mineral Oil Viscosity Standard fluids*

**Container size:** For Viscosity Standards < 30,000 cP, use a 600 ml Low Form Griffin Beaker having a working volume of 500 ml.

For Viscosity Standards  $\geq$  30,000 cP, use the fluid container.

Inside Diameter: 3.25" (8.25 cm)

Height: 4.75" (12.1 cm)

**Note:** Container may be larger, but may NOT be smaller!

**Temperature:** As stated on the fluid standard label ( $\pm$ ) 0.1°C

### **Brookfield Viscosity Standard Fluid General Information**

We recommend that Brookfield Viscosity Standard Fluids be replaced on an annual basis, one year from date of initial use. These fluids are pure silicone and are not subject to change over time. However, exposure to outside contaminants through normal use requires replacement on an annual basis. Contamination may occur by the introduction of solvent, standard of different viscosity or other foreign material.

Viscosity Standard Fluids may be stored under normal laboratory conditions. Disposal should be in accordance with state, local, and federal regulations as specified on the material safety data sheet.

Brookfield Engineering Laboratories does not re-certify Viscosity Standard Fluids. We will issue duplicate copies of the Certificate of Calibration for any fluid within two years of purchase date. Brookfield Viscosity Standard Fluids are reusable provided they are not contaminated. Normal practice for usage in a 600 ml beaker is to return the material from the beaker back into the bottle. When using smaller volumes in accessories such as the Small Sample Adapter, UL Adapter, or Thermosel, the fluid is normally discarded.

### **Calibration Check Procedure**

- 1) Shut off the rheometer.
- 2) Place the viscosity standard fluid (in the proper container) into the water bath.
- 3) Press and hold the  $\uparrow$  and  $\downarrow$  keys simultaneously while turning the rheometer power ON. Figure C1 appears on the rheometer display.



```
RHEOMETER SETUP
ENTER TO START
```

*Figure C1*

- 4) Press the **ENTER** key and Figure C2 appears on the rheometer display.

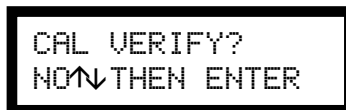

```
CAL VERIFY?
NO THEN ENTER
```

*Figure C2*

Using the  $\uparrow$  or  $\downarrow$  key, set the **CAL VERIFY** setting to **YES**, then press the **ENTER** key. Figure C3 appears on the rheometer display. Ensure the rheometer is level, and remove any attached spindle before auto-zeroing.



REMOVE SPINDLE  
PRESS ANY KEY

*Figure C3*

- 5) After pressing a key, Figure C4 is displayed with the text flashing.



AUTOZEROING  
RHEOMETER

*Figure C4*

When the auto-zero is complete, Figure C5 appears on the rheometer display with OFFRPM flashing.



CP 0.00      S71  
% 0.0      OFFRPM

*Figure C5*

- 6) Attach the spindle to be used in the calibration check and lower it into the appropriate Brookfield Viscosity Standard Fluid.

**Note:** Avoid trapping air bubbles beneath any surface of the spindle by first immersing the spindle in the fluid at an angle, then connecting it to the rheometer.

- 7) The viscosity standard fluid, together with the spindle, should be immersed in the bath for a minimum of one (1) hour, stirring the fluid periodically, prior to taking measurements.
- 8) After one (1) hour, check the temperature of the viscosity standard fluid with an accurate thermometer.
- 9) If the fluid is at test temperature ( $\pm 0.1^\circ\text{C}$  of the specified temperature, normally  $25^\circ\text{C}$ ), measure the viscosity according to the following steps and record the reading.
- 10) Use the  $\uparrow$  and  $\downarrow$  keys to select the speed to be used for the calibration check. Speeds between 0.1 and 100 rpm are available for use in checking the calibration. Once a speed is selected by pressing the **ENTER** key, the spindle rotates at this speed, and % Torque and a Viscosity value are displayed, and the S71 begins flashing.
- 11) Use the  $\uparrow$  and  $\downarrow$  keys to select the spindle to be used for the calibration check. All standard Brookfield spindles in addition to any pre-programmed special spindles may be used to check the calibration of the instrument. Once a spindle is selected by pressing the **ENTER** key, the viscosity value is computed and displayed. Pressing the enter key toggles between the spindle and speed fields.

**Note:** The spindle must rotate at least five (5) times before readings are taken.

- 12) The viscosity reading should equal the cP value on the viscosity fluid standard to within the combined accuracies of the Rheometer and the viscosity standard fluid as discussed in the following section (Interpretation of Calibration Test Results).

- 13) When the calibration check is complete, switch off the rheometer or press the **ESC** key if you wish to Print Parameter RAM (see Appendix H – Fault Diagnosis and Troubleshooting).

**Interpretation of Calibration Test Results:**

When verifying the calibration of the YR-1 Rheometer, the instrument and viscosity standard fluid error must be combined to calculate the total allowable error.

The YR-1 is accurate to  $\pm 2\%$  of any full scale spindle/speed viscosity range for vane spindles and  $\pm 1\%$  of any full scale spindle/speed viscosity range for all other Brookfield spindles.

Brookfield Viscosity standard Fluids are accurate to  $\pm 1\%$  of their stated value.

**Example:** Calculate the acceptable range of viscosity using the RVYR-1 Rheometer and V-71 spindle at 2 RPM; Brookfield Standard Fluid 12,500 with a viscosity of 12,257 cP at 25°C:

- 1) Calculate full scale viscosity range using the equation:

$$\text{Full Scale Viscosity Range [cP]} = \text{TK} * \text{SMC} * \frac{10,000}{\text{RPM}}$$

Where:

TK = 1.0 from **Table A2**

SMC = 2.62 from **Table A1**

$$\text{Full Scale Viscosity Range } \frac{1 * 2.62 * 10,000}{2} = 13,100 \text{ cP}$$

The viscosity is accurate to  $\pm 262$  cP (which is 2% of 13,100)

- 2) The viscosity standard fluid is 12,257 cP. Its accuracy is  $\pm 1\%$  of 12,257 or  $\pm 123$  cP.
- 3) Total allowable error is  $262 + 123 \text{ cP} = \pm 385 \text{ cP}$ .
- 4) Therefore, any viscosity reading between 11,872 and 12,642 cP indicates that the YR-1 Rheometer is operating correctly. Any reading outside these limits may indicate a problem. Contact the Brookfield technical sales department or your local Brookfield dealer with test results to determine the nature of the problem.

## APPENDIX D - Calculations

The following equations can be used to calculate the shear stress values after each packet of data is obtained from the YR-1:

$$\tau = \frac{TK \times YMC \times T}{10}$$

where:

- $\tau$  = Yield Stress (Pascals)
- TK = Model Torque Constant from Table A2 in Appendix A
- YMC = Yield Multiplier Constant from Table A1 in Appendix A
- T = % Torque reading

The following equations can be used to calculate the strain data after each packet of data is obtained from the YR-1:

$$\gamma = \theta_M - (S \times T)$$

where:

- $\gamma$  = Strain (rad)
- $\theta_M$  = Angular rotation of motor shaft (rad)
- S = Radial Spring Factor (rad/% torque)
- T = % Torque reading (%)

$$\theta_M = \omega \times t \times \frac{2\pi}{60}$$

where:

- $\theta_M$  = Angular distance of motor shaft (rad)
- $\omega$  = Speed (rpm)
- t = time of test (seconds)

$$S = \theta_{cal} \times (2\pi) \times 0.01$$

where:

- S = Radial spring factor (rad/%torque)
- $\theta_{cal}$  = Spring windup angle (revolutions)

$$\theta_{\text{cal}} = \frac{(V_{\text{cal}} \times t_{\text{cal}})}{60000}$$

where:

$\theta_{\text{cal}}$	=	Spring windup angle	(revolutions)
$V_{\text{cal}}$	=	Calibration speed (fixed at 0.1 rpm)	(rpm)
$t_{\text{cal}}$	=	Calibration time (time for 0% to 100% spring wind up)	(milliseconds)

$$t_{\text{cal}} = \frac{\text{bi}}{b_{\text{cal}}} \times \frac{V}{V_{\text{cal}}} \times 100$$

$t_{\text{cal}}$	=	Calibration time (time for 0% to 100% spring windup during calibration)	(milliseconds)
$\text{bi}$	=	Base increment	(milliseconds)
$b_{\text{cal}}$	=	base increment calibration torque	(%torque/base increment)
$V$	=	Speed	(rpm)
$V_{\text{cal}}$	=	Calibration speed (fixed at 0.1 rpm)	(rpm)

## APPENDIX E - Communications

### 1. Serial (RS-232) Communications Parameters

Baud Rate 9600  
Data Bits 8  
Stop Bits 1  
Parity None  
Handshake None

### 2. RS-232 Output During The Test

All output that occurs immediately before and after the test is described in Sections 4.2 and 4.3. That pre- and post- test output is sent out both the serial (RS-232) and parallel ports. When using the Brookfield Computer Cable (Brookfield part # DVP-80), the YR-1 will output a data string during the actual yield test run. This data is **ONLY** sent out to the RS-232 port for use with the EZ-Yield software.

The following output is sent to the serial (RS-232) port at the end of every Base Increment period:

**xxxxxx:yy.yy:ttt.t:zz.zz**

where the delimiter between all fields is a colon (:) character and

**xxxxxx** = The **Base Increment** count in hexadecimal format, padded with leading zeroes.

This is the time, in milliseconds that each reading was taken in the instrument.

**yy.yy** = % **Torque** value. % Torque is output with a resolution 0.01% with a maximum of 99.99%.

**ttt.t** = **Temperature** in °C.

**zz.zz** = **Delta Torque** (%). This is the actual change in percent torque, measured from the previous reading, calculated at the end of each Base Increment period.

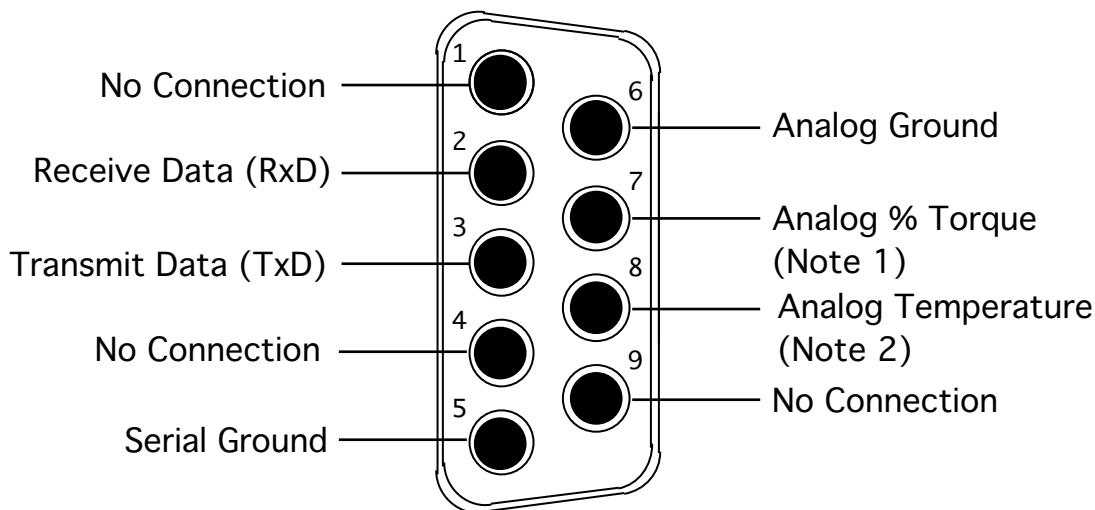

#### Notes:

1. This is a 0-1 volt d.c. output where 0 volts corresponds to 0% torque and 1 volt corresponds to 100 % torque with a resolution of 1 millivolt (0.1%).
2. This is a 0-4 volt d.c. output where 0 volts corresponds to -100°C and 4 volts corresponds to +300°C with a resolution of 1 millivolt (0.1°C).

### **Analog Output:**

The analog outputs for temperature and % torque are accessed from the 9-pin connector located on the rear panel of the YR-1. The pin connections are shown in Figure E1. The output cable (Part No. DVP-96Y) connections are:

**Red Wire:** Temperature Output  
**Black Wire:** Temperature Ground  
**White Wire:** % Torque Output  
**Green Wire:** % Torque Ground

Please contact Brookfield Engineering Laboratories or your local dealer/distributor for purchase of the DVP-96Y analog output cable.

See Appendix D to use the data acquired during a test to perform the appropriate calculations.

# APPENDIX F - Model S Laboratory Stand

## PARTS IDENTIFICATION & INSTRUCTIONS

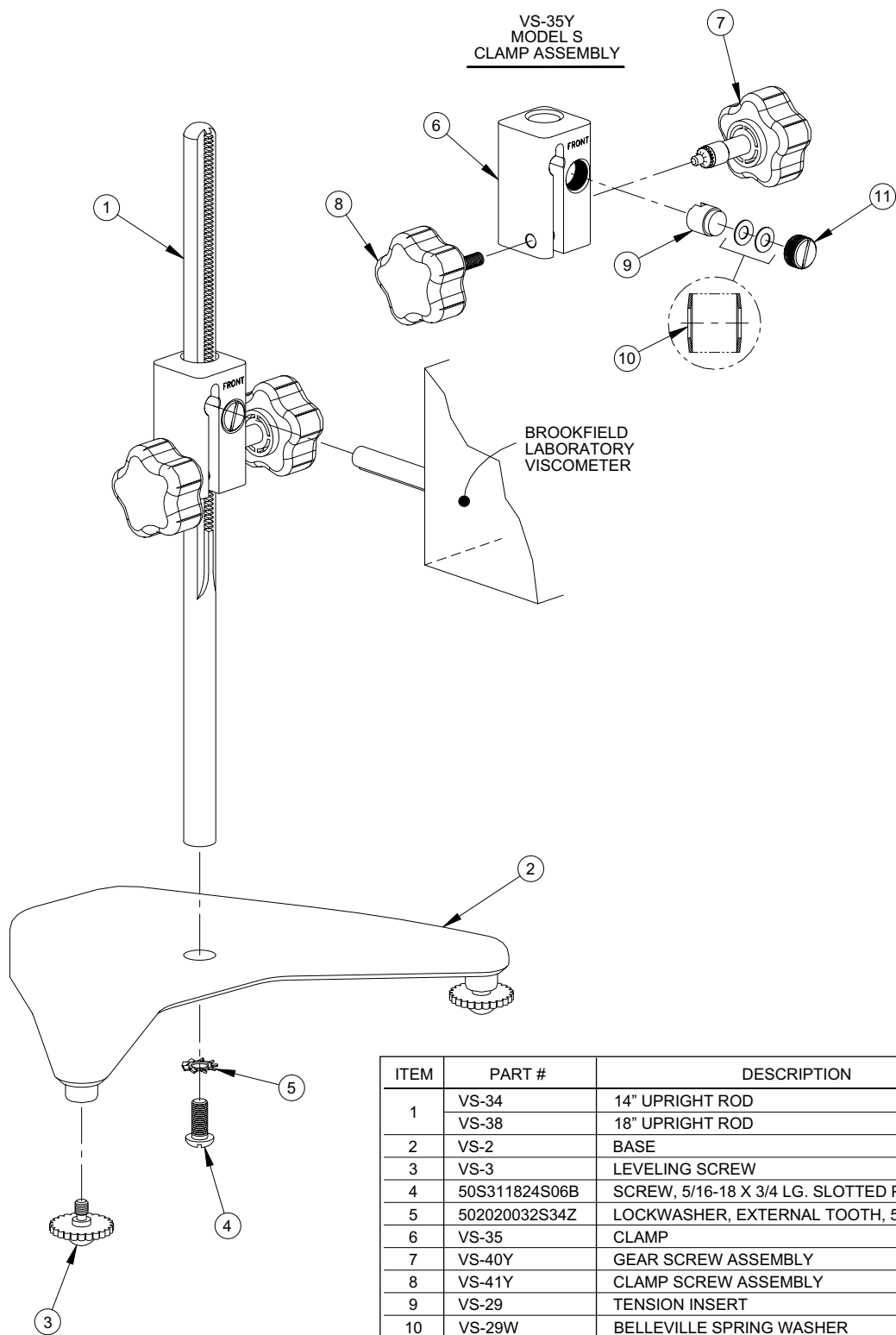

ITEM	PART #	DESCRIPTION	QTY.
1	VS-34	14" UPRIGHT ROD	1
	VS-38	18" UPRIGHT ROD	OPTIONAL
2	VS-2	BASE	1
3	VS-3	LEVELING SCREW	2
4	50S311824S06B	SCREW, 5/16-18 X 3/4 LG. SLOTTED PAN HD.	1
5	502020032S34Z	LOCKWASHER, EXTERNAL TOOTH, 5/16 X 5/8 X 1/32	1
6	VS-35	CLAMP	1
7	VS-40Y	GEAR SCREW ASSEMBLY	1
8	VS-41Y	CLAMP SCREW ASSEMBLY	1
9	VS-29	TENSION INSERT	1
10	VS-29W	BELLEVILLE SPRING WASHER	2
11	VS-28	TENSION SCREW	1

## Unpacking

Check carefully to see that all the components are received with no concealed damage.

- 1 Base, VS-2, with 2 Leveling Screws, VS-3, packed in a cardboard carton
- 1 Upright Rod, VS-34, with attached Clamp Assembly, VS-35Y

## Assembly (Refer to Figure F1)

1. Remove the base assembly from the carton.
2. Remove the screw and washer from the upright rod. Place the rod and clamp assembly into the hole in the top of the base.  
**Note:** The “Front” designation on the clamp assembly should face the opening of the legs, i.e., parallel to the leveling feet.
3. Rotate the rod/clamp assembly slightly until the slot on the bottom of the rod intersects the pin located in the base.
4. While holding the rod and base together, insert the slotted screw and washer as shown and tighten securely.

## YR-1 Rheometer Mounting

Insert the YR-1 Rheometer mounting rod into the hole (with the cut-away slot) in the clamp assembly. Adjust the instrument level until the bubble is centered from right to left and tighten the clamp knob (clockwise). Use the leveling screws to “fine” adjust the viscometer level. **Note: If the Rheometer cannot be leveled, check to insure that the rod is installed with the gear rack facing forward.**

**Note:** If the clamp is taken off the upright rod, the tension insert (Part No. VS-29) must be properly aligned for the clamp to fit back onto the upright rod. When the tension insert (Part No. VS-29) is inserted, its slot must be in the vertical position parallel to the upright rod. If the slot is not in the correct position, the clamp will not slide down over the upright rod. Use a small screwdriver or pencil to move it into the correct position. The VS-29W Belleville spring washers must face each other as illustrated. Adjust the VS-28 tension screw so that the clamp assembly is not loose on the upright rod.

**CAUTION: Do not tighten the clamp knob unless the viscometer mounting rod is inserted in the clamp assembly.**

Center the YR-1 relative to the stand base and retighten the jam nut as required. Referring to the Rheometer bubble level, adjust the leveling screws until the instrument is level.

## APPENDIX G - DVE-50 Probe Clip

Probe Clip DVE-50 is supplied with all model YR-1 Rheometers. It is used to attach the RTD temperature probe to low form Griffin beaker. Figure G1 is a view of the Probe Clip, showing the hole into which the RTD probe is inserted. When inserting the RTD probe into the Probe Clip, the upper part of the Clip is compressed by squeezing the points shown in Figure G1.

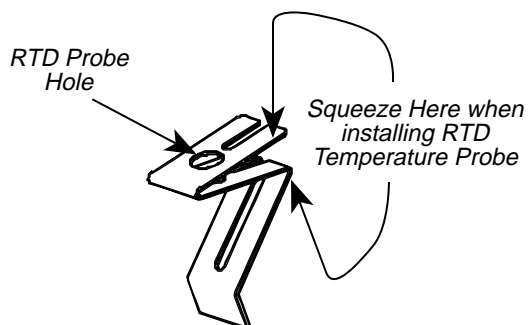

Figure G1

Figure G2 shows the probe clip mounted in a 600 ml low form Griffin beaker.

**Note:** The RTD probe must be parallel to the beaker wall so as not to interfere with the yield measurement.

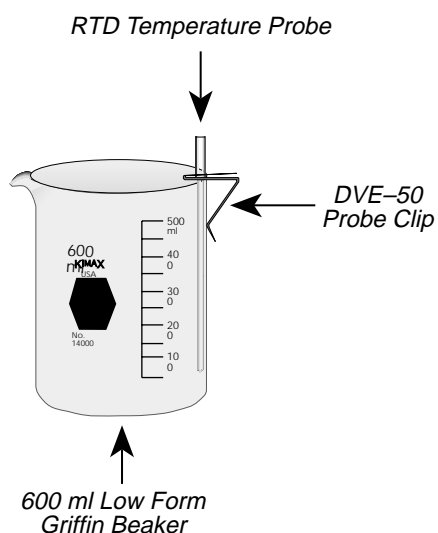

Figure G2

## APPENDIX H - Fault Diagnosis and Troubleshooting

Listed are some of the more common problems that you may encounter while using your YR-1 Rheometer.

### Spindle Does Not Rotate

- ✓ Make sure the rheometer is plugged in.
- ✓ Check the voltage rating on your rheometer (115, 220V); it must match the AC supply voltage.
- ✓ Make sure the motor is ON and the desired rpm is selected.

### Spindle Wobbles When Rotating or Looks Bent

- ✓ Make sure the spindle is tightened securely to the rheometer coupling.
- ✓ Check the straightness of spindle vanes; replace spindle if bent or warped.
- ✓ Inspect rheometer coupling and spindle coupling mating areas and threads for dirt; clean threads on spindle coupling with a 3/56 left-hand tap.
- ✓ Inspect threads for wear; if the threads are worn, the unit needs service (see Appendix I). Check to see if spindles rotate eccentrically or wobble. There is an allowable runout of 1/32-inch in each direction (1/16-inch total) when measured from the bottom of the spindle rotating in air.
- ✓ Check to see if the rheometer coupling appears bent; if so, the unit is in need of service (see Appendix I, “How to Return Your Rheometer”).

If you continue to experience problems with your rheometer, follow this troubleshooting section to help isolate potential problems.

### Perform an Oscillation Check

- ✓ Press and hold the  $\uparrow$  and  $\downarrow$  arrow keys simultaneously while turning the rheometer power **ON**. When prompted with **CAL VERIFICATION** on the display, use the arrow keys to select **YES**, then press the **ENTER** key. Ensure no spindle is attached before Auto-zeroing.
- ✓ With the rheometer set to zero (0) rpm, gently push up on the rheometer coupling.
- ✓ Turn the coupling until the display % torque reads 10-15.
- ✓ Gently let go of the coupling.
- ✓ Watch the display; you should see the torque value return to 0.0 (+/- 0.1).

If the digital display does not return to ZERO, the unit is in need of service (see Appendix I, “How to Return Your Rheometer”).

#### Inaccurate Readings

- ✓ Verify spindle, speed and model selection.
- ✓ Verify that % Torque readings are greater than or equal to 10%.
- ✓ Verify test parameters: Yield Test Parameters, container, volume and method. Refer to Appendix C, “Variables in Yield Measurements”.
- ✓ Perform a calibration check; follow the instructions in Appendix B, “Calibration Procedures”.
- ✓ Verify tolerances are calculated correctly.

If the unit is found to be out of tolerance, the unit may be in need of service. See Appendix I for details on “How to Return Your Rheometer”.

#### Rheometer Will Not Return to Zero

- ✓ Rheometer is not level
  - Check with spindle out of the sample
  - Adjust the laboratory stand
- ✓ Pivot point or jewel bearing faulty
  - Perform calibration check. See Appendix C, “Calibration Procedures”.
  - Contact Brookfield Engineering Laboratories, Inc. or your Brookfield dealer for repair

#### Display Reading Will Not Stabilize

- ✓ Rheometer is not level
  - Check with spindle out of the sample
  - Adjust the laboratory stand
- ✓ Special characteristic of sample fluid. There is no problem with the rheometer.
- ✓ Check for erratic spindle rotation.
  - Verify power supply
  - Contact Brookfield Engineering Laboratories, Inc. or your Brookfield dealer for repair
- ✓ Bent spindle or spindle coupling.
  - Contact Brookfield Engineering Laboratories, Inc. or your Brookfield dealer for repair
- ✓ Temperature fluctuation in sample fluid
  - Use temperature bath control.

No Recorder Response

- ✓ Be Sure the rheometer is not at ZERO reading.
- ✓ Be sure the recorder is ON and not on STANDBY.
- ✓ Verify the range settings.
- ✓ Check cable leads for clean connection.

Recorder Pen Moves in Wrong Direction

- ✓ Output polarity reversed
  - Reverse leads

Rheometer Will Not Communicate with PC

- ✓ Check the comm port setting and make sure the correct port on the PC is being utilized.
- ✓ Ensure that the rheometer has the appropriate communications cable (Communications) connected to it and that the opposite end of the cable is connected to a valid COM (serial) port on the host PC).
- ✓ Ensure that the rheometer is powered ON.
- ✓ Ensure that the appropriate COM port is selected on the Main Toolbar of the EZ-Yield software.
- ✓ If there is still erratic or no communication, check the following:
  - Click the START button. Select “Settings” then “Control Panel”. Double click the “System” icon. Select the “Device Manager” tab. Select “Ports”, highlight the COM port in use and click the “Properties” button (or double-click the COM port in use). Click “Port Settings” then “Advanced”.
  - Ensure the check box labeled “Use FIFO buffers (requires 16550 compatible UART)” is checked. Ensure that the sliders for the “Receive Buffer” and the “Transmit Buffer” are both set all the way to the left (Low). Click the OK buttons to accept the changes and get back to the desktop.
  - If there is still a communication problem, follow the above procedure, but this time, uncheck the box labeled “Use FIFO buffers (requires 16550 compatible UART)”. Again, check the OK buttons to accept the changes.
- ✓ Check the interconnecting cable for proper installation.

If the above do not rectify the problem, perform the following:

- ✓ Shut off the rheometer.
- ✓ Attach a printer to the parallel port.
- ✓ Press and hold the ↑ and ↓ keys simultaneously while turning the rheometer power ON. Figure H1 appears on the rheometer display:



*Figure H1*

Press the **ENTER** key and Figure H2 appears.

```
CAL VERIFY?  
NO↑↓THEN ENTER
```

*Figure H2*

Ensure NO is displayed then press the **ENTER** key and Figure H3 appears.

```
PRINT PARAM RAM?  
NO↑↓THEN ENTER
```

*Figure H3*

Using the **↑** and **↓** key, scroll to YES and press the **ENTER** key. Figure H4 appears.

```
READY PRINTER  
ENTER TO START
```

*Figure H4*

Press the **ENTER** key. Information similar to Figure H5 is printed on the attached printer.

Printer Port		Parallel
Special Spindle AA	SMC	0000.000
Special Spindle AA	SRC	00.000
Special Spindle BB	SMC	0000.000
Special Spindle BB	SRC	00.000
Special Spindle CC	SMC	0000.000
Special Spindle CC	SRC	00.000
Special Spindle DD	SMC	0000.000
Special Spindle DD	SRC	00.000
Special Spindle EE	SMC	0000.000
Special Spindle EE	SRC	00.000
Viscometer Model		5HB
Raw Temps		3A1E 039E
Torque Scale		D324
Yield Constant		125158.7

*Figure H5*

- ✓ Contact Brookfield or our authorized dealer to review the information printed in the last step.
- ✓ Figure H6 next appears on the rheometer display. Turn the rheometer power OFF.

```
SETUP COMPLETE  
TURN POWER OFF
```

*Figure H6*

## APPENDIX I - Warranty Repair and Service

### Warranty

Brookfield Rheometers are guaranteed for one year from date of purchase against defects in materials and workmanship. They are certified against primary viscosity standards traceable to the National Institute of Standards and Technology (NIST). The Rheometer must be returned to **Brookfield Engineering Laboratories, Inc.** or the Brookfield dealer from whom it was purchased for no charge warranty service. Transportation is at the purchaser's expense. The Rheometer should be shipped in its carrying case together with all spindles originally provided with the instrument.

For repair or service in the **United States** return to:

**Brookfield Engineering Laboratories, Inc.**

11 Commerce Boulevard  
Middleboro, MA 02346 U.S.A.

Telephone: (508) 946-6200 FAX: (508) 946-6262  
<http://www.brookfieldengineering.com>

For repair or service **outside the United States** consult **Brookfield Engineering Laboratories, Inc.** or the dealer from whom you purchased the instrument.

For repair or service in the **United Kingdom** return to:

**Brookfield Viscometers Limited**

1 Whitehall Estate  
Flex Meadow  
Pinnacles West  
Harlow, Essex CM19 5TJ, United Kingdom

Telephone: (44) 27/945 1774 FAX: (44) 27/945 1775

For repair or service in **Germany** return to:

**Brookfield Engineering Laboratories Vertriebs GmbH**

Hauptstrasse 18  
D-73547 Lorch, Germany

Telephone: (49) 7172/927100 FAX: (49) 7172/927105

## Packaging Instructions to Return a Rheometer for Repair or Calibration

- Remove and return all spindles (properly packed for shipping).
- Clean excess testing material off the instrument.
- Include MSDS sheets for all materials tested with this instrument.
- Support pointer shaft with white, nylon shipping cap, as shown in Figure I1, or with white plastic shipping cap originally supplied with instrument.
- Pack the instrument in its original case. Cases are available for immediate shipment from Brookfield. If the case is not available, take care to wrap the instrument with enough material to support it. Avoid using foam peanuts or shredded paper.
- DO NOT send the laboratory stand unless there is a problem with the upright rod, clamp or base. If there is a problem with the stand, remove the upright rod from the base and individually wrap each item to avoid contact with the instrument. Do not put lab stand in rheometer carrying case.
- Fill out a copy of the Rheometer Information Sheet (on the following page) with as much information as possible to help expedite your service. If you do not use this form, please include a memo indicating the type of problem you are experiencing or the service you need performed. Please also include a purchase order number for us to bill against.
- Package the instrument and related items in a strong box for shipping. Mark the outside of the box with handling instructions.

**Example:** "Handle with Care" or  
"Fragile - Delicate Instrument"

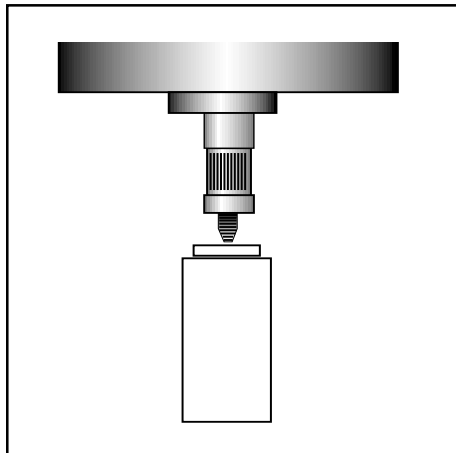

*Figure I1*

Providing us with the following information will help us to service your equipment more quickly and efficiently. Please photocopy, fill out and return a copy of this form with your instrument.

Brookfield recommends that all viscometers be returned for annual calibration to ensure that your equipment continues to provide the same accuracy you have come to expect from Brookfield products.

<b>1</b>	<b>RHEOMETER INFORMATION</b>
	<b>Serial Number:</b> _____ <b>Date:</b> _____ <b>Model:</b> _____

<b>2</b>	<b>COMPANY INFORMATION</b>
	Company: _____ Primary User: _____ Telephone: _____ Fax: _____ P.O. Number: _____ (to cover repair and shipping) Billing Address: _____ Shipping Address: _____ _____ _____ _____ Return Shipment Instructions: UPS ground <input type="checkbox"/> UPS Next Day <input type="checkbox"/> UPS 2nd Day <input type="checkbox"/> Federal Express <input type="checkbox"/> _____ (Federal Express Account Number required)

<b>3</b>	<b>SERVICE INFORMATION</b>
	Operating Conditions (Spindle; Speed; Temp. Control; Temperature of Sample): _____ _____ _____ Did you contacting Brookfield before returning this instrument? Y <input type="checkbox"/> N <input type="checkbox"/> If yes, whom did you contact? _____ Description/Symptoms of Present Problem/Malfunction (please list all): _____ _____ _____ Time Since Last Serviced (if known): _____ Before & After Calibration Check? Y <input type="checkbox"/> N <input type="checkbox"/> Other Comments: _____ _____ _____

<b>STEPS:</b> <input type="checkbox"/> Return the rheometer to the attention of the Repair Department at the address above. <input type="checkbox"/> Package the rheometer for shipment, as outlined on the preceding page. <input type="checkbox"/> Include a purchase order or purchase order number with this form.
--